

# BÖWE PASSAT

*Ersatzteil-  
Katalog*

*Spare Parts  
Catalogue*

P 540  
P 546

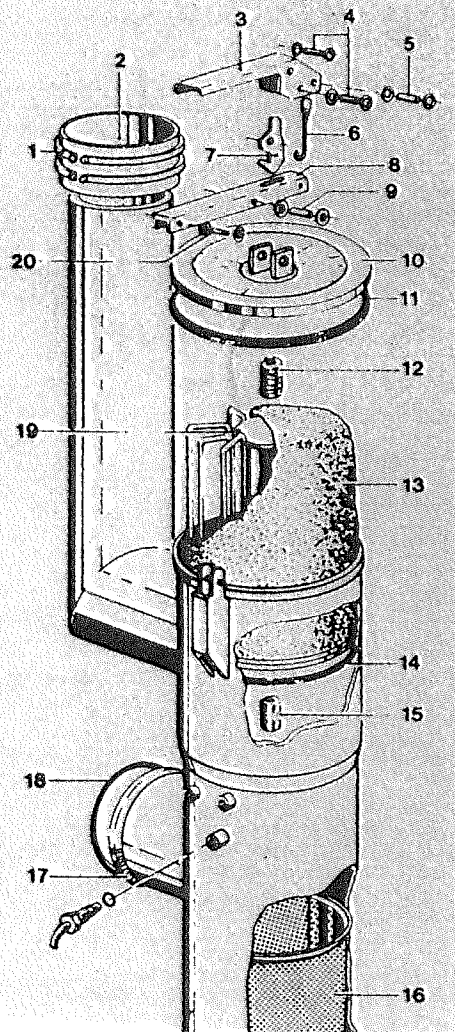

DIE FÜNFTE  
GENERATION

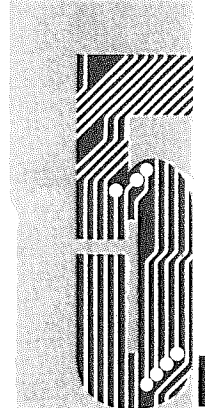

THE FIFTH  
GENERATION

Der Inhalt entspricht unserem besten Wissen und basiert auf dem Stand der Technik. Rechtsverbindlichkeiten können nicht hergeleitet werden. Technische Änderungen vorbehalten. Nachdruck oder Vervielfältigung nur mit unserer ausdrücklichen Genehmigung.

The contents are correct to the best of our knowledge and belief and correspond to the present level of technology. No legal claims can be derived. Technical modifications reserved. Reproduction or duplication only with our express permission.

Cette documentation rédigée au mieux de nos connaissances, est basée sur le dernier standard de la technologie. Il ne saurait en résulter aucune responsabilité de notre part. Toute modification réservée. Toute reproduction interdite sauf notre autorisation expresse.

El contenido basa sobre la recién experiencia ganada en la tecnología. No asumimos responsabilidad alguna. Se reservan todos los derechos de modificación. Reproducción o multiplicación - sólo permitida con expresa autorización de la BÖWE.

**ERSATZTEILKATALOG**

**SPARE PARTS CATALOGUE**

**CATALOGUE DE PIECES DE RECHANGE**

**CATALOGO DE REPUESTOS**

**P 540**

**P 546**

**BÖWE PASSAT**  
Reinigungs- und Wäschereitechnik GmbH  
Postfach 101380, D-86003 Augsburg  
Telefon (08 21) 570 20, Fax (08 21) 570 23 51, Tx 536480 boe d

## WICHTIGE HINWEISE ZUR ERSATZTEIL-BESTELLUNG

Bei allen Ersatzteil-Bestellungen sind Maschinenbezeichnung, Fabrik-Nummer, Baujahr und Betriebsspannung anzugeben.

Die Bestellung der einzelnen Ersatzteile erfordert folgende Angaben: Stückzahl - Sachnummer - Bezeichnung.

Bei elektrischen Komponenten sind zusätzlich Spannung und Frequenz anzugeben.

### Bestellbeispiel:

P 540, 104/8903, 400 V, 50 Hz  
2 Stck, 079261 Flanschdichtung

Die im Ersatzteilkatalog mit Sachnummern angegebenen Ersatzteile sind normalerweise kurzfristig lieferbar.

Die mit einem \* versehenen Sachnummern bezeichnen komplette Einheiten.

Das BÖWE-Werk arbeitet ständig an der Weiterentwicklung aller Produkte. Bitte haben Sie Verständnis dafür, daß wir uns daher jederzeit Änderungen des Lieferumfangs in Form, Ausstattung und Technik vorbehalten müssen. Aus den Angaben, Abbildungen und Beschreibungen des Ersatzteilkataloges können deshalb keine Ansprüche hergeleitet werden.

## AVIS IMPORTANT CONCERNANT LA COMMANDE DE PIÉCES DÉTACHÉES

Pour toute commande de pièces détachées, veuillez ne pas oublier d'indiquer le type de machine, le numéro et l'année de fabrication, ainsi que la tension de service.

La commande des diverses pièces détachées devra comprendre: nombre de pièces - no. de référence - désignation

Si vous commandez des composants électriques, indiquez en outre le voltage et la fréquence.

### Exemple de bon de commande:

P 540, 104/8903, 400 V, 50 Hz  
2 unités 079261 garniture d'étanchéité de bride

Dans le catalogue, les pièces détachées suivies du no. de référence sont généralement livrables à court terme.

Les numéros de référence munis d'un astérisque (\*) désignent des éléments complets.

L'usine BÖWE travaille continuellement au développement de ses fabrications.

Nous sommes persuadés que vous comprendrez que nous nous réservons, à tout moment, le droit de modifier l'étendue de la livraison dans sa forme, dans son équipement et son exécution technique.

De ce fait, nous ne pouvons prendre aucun engagement concernant les précisions, illustrations et descriptions données dans ce catalogue de pièces détachées.

## IMPORTANT POINTS TO NOTE WHEN ORDERING SPARE PARTS

In every spare parts order it is essential to state machine model, serial number, year of construction and operating voltage.

For the individual parts ordered the following data is needed: Quantity - part number (SN) - designation.

In the case of electrical components voltage and frequency must also be stated.

### Example:

P 540, 104/8903, 400 V, 50 Hz  
2 079261 flanged gasket

The parts with a number (SN) in the catalogue are normally available at short notice.

The part numbers marked \* refer to complete units.

At the BÖWE works we are constantly at work on the further development of all products. We are sure you will appreciate our need to reserve the right to change form, equipment and technology at any time. No liability can be derived from data, illustrations and descriptions in the spare parts catalogue.

## AVISOS IMPORTANTES PARA PEDIDOS DE REPUESTOS

Al pedir repuestos hay que indicar la designación de la máquina, el número de fabricación, el año de fabricación, y la tensión de servicio.

Al pedir los diversos repuestos deberá indicarse el número de piezas, el número de referencia, y la designación.

Al pedir componentes electrónicos hay que indicar además la tensión y la frecuencia.

### Ejemplo:

P 540, 104/8903, 400 V, 50 Hz  
2 079261 Empaquetadura de brida

Los repuestos marcados con números de referencia en el Catálogo de Repuestos normalmente pueden suministrarse rápidamente.

Los números de referencia marcados con \* se refieren a unidades completas.

La fábrica BÖWE está trabajando constantemente en el desarrollo ulterior de todos sus productos.

Por esta razón, tenemos que reservarnos el derecho de modificar en cualquier momento el volumen de suministro respecto a su forma, equipamiento y tecnología.

Por consecuencia, no podemos asumir ninguna responsabilidad por los datos, las ilustraciones y las descripciones del Catálogo de Repuestos.

## ISO IMPORTANTE PER L'ORDINAZIONE DI PEZZI DI CAMBIO

tutte le ordinazioni di pezzi di ricambio è solitamente necessario indicare il modello di macchina, il numero di macchina, l'anno di costruzione ed il voltaggio d'esercizio.

Impronta per l'ordinazione di pezzi di ricambio corrono numero di pezzi - numero SN - modello di macchina.

Suggeriamo precisare ancora la tensione e la frequenza i componenti elettrici da ordinare.

### esempio di ordinazione:

P 540, 104/8903, 400 V, 50 Hz

2 pezzi 079261 guarnizione a flangia

pezzi di ricambio muniti di numero nel catalogo i pezzi di ricambio sono normalmente pronti all'uso. I numeri di pezzi dotati di \* designano gli organi completi.

Il BÖWE provvedere continuamente all'ulteriore sviluppo di tutti i prodotti. Abbiamo, quindi, della comprensione se dobbiamo perciò riservarci il diritto di modifica della fornitura, per quanto riguarda la forma, la dotazione di accessori e la tecnologia.

I dati, dalle illustrazioni e dalle descrizioni cui al catalogo dei pezzi di ricambio non possono quindi derivare diritti di sorta.

## ВАЖНЫЕ УКАЗАНИЯ ДЛЯ ЗАКАЗА ЗАПЧАСТЕЙ

При заказе запчастей указание названия машины, номера машины, года изготовления и напряжения всегда необходимо.

При заказе отдельных запчастей необходимо указание следующих: количество, номер части, наименование.

При электрических компонентах обязательно указать тоже напряжение и частоту.

### пример заказа:

P 540, 104/8903, 400 V, 50 Hz

шт. 079261 уплотнение

Упомянутые запчасти нормально поставляются краткосрочно.

Так обозначенные в каталоге номера показывают комплектные узлы.

Производ BÖWE постоянно работает над дальнейшим развитием всей продукции. Поэтому поймите пожалуйста, что мы в любое время можем поставить за собой право изменить объем поставки по форме, виду и технике.

Из данных, рисунков и описаний каталога запчастей поэтому нельзя выводить каких-либо требований.

## DŮLEŽITÁ UPOZORNĚNÍ TÝKAJÍCÍ SE OBJEDNÁVEK NÁHRADNÍCH DÍLŮ

Při všech objednávkách náhradních dílů uvádějte typové označení, výrobní číslo, rok výroby, provozní napětí.

Při objednávkách jednotlivých náhradních dílů jsou nutně následující údaje: počet - č. výrobku - označení.

Při elektrických komponentech je nutno navíc uvést napětí a frekvenci.

### Příklad objednávky:

P 540, 104/8903, 400 V, 50 Hz

2 kusy 079261 těsnění přírub

Náhradní díly označené v katalogu číslem jsou dodávány obvykle v krátké lhůtě.

Hvězdičkou označená čísla náhradních dílů označují kompletní celky.\*

Podnik BÖWE nepřetržitě pracuje na dalším vývoji všech svých výrobků. Proto Vás prosíme o pochopení při případných změnách ohledně rozsahu, tvaru, vybavení a techniky.

Z údajů, vyobrazení a popisu v katalogu náhradních dílů nelze vyvozovat žádné nároky.

## WAŻNE WSKAZÓWKI DO ZAMAWIANIA CZĘŚCI ZAMIENNYCH

Przy każdym zamówieniu części zamiennych należy podać rodzaj maszyny, numer fabryczny, rok budowy i natężenie zakładowe.

Przy zamawianiu poszczególnych części zamiennych należy podać następujące dane: ilość, numer części oznaczenie.

Przy składnikach elektrycznych należy dodatkowo podać natężenie i częstotliwość.

### Przykład zamówienia:

P 540, 104/8903, 400 V, 50 Hz

2 sztuki 079261 uszczelnienie kołnierzowe

Części zamienne oznaczone w katalogu części zamiennych numerem części mogą być dostarczone natychmiast.

Numerы części oznaczone znakiem \* oznaczają pełne zestawy.

Firma BÖWE pracuje ciągle nad ulepszeniem wszystkich produktów. W związku z tym prosimy o zrozumienie, że w każdej chwili możemy zmienić formę, wyposażenie lub stan techniczny zamówienia. Z zamieszczonych w katalogu części zamiennych danych, opisów i rysunków nie mogą być wysuwane żadne roszczenia.

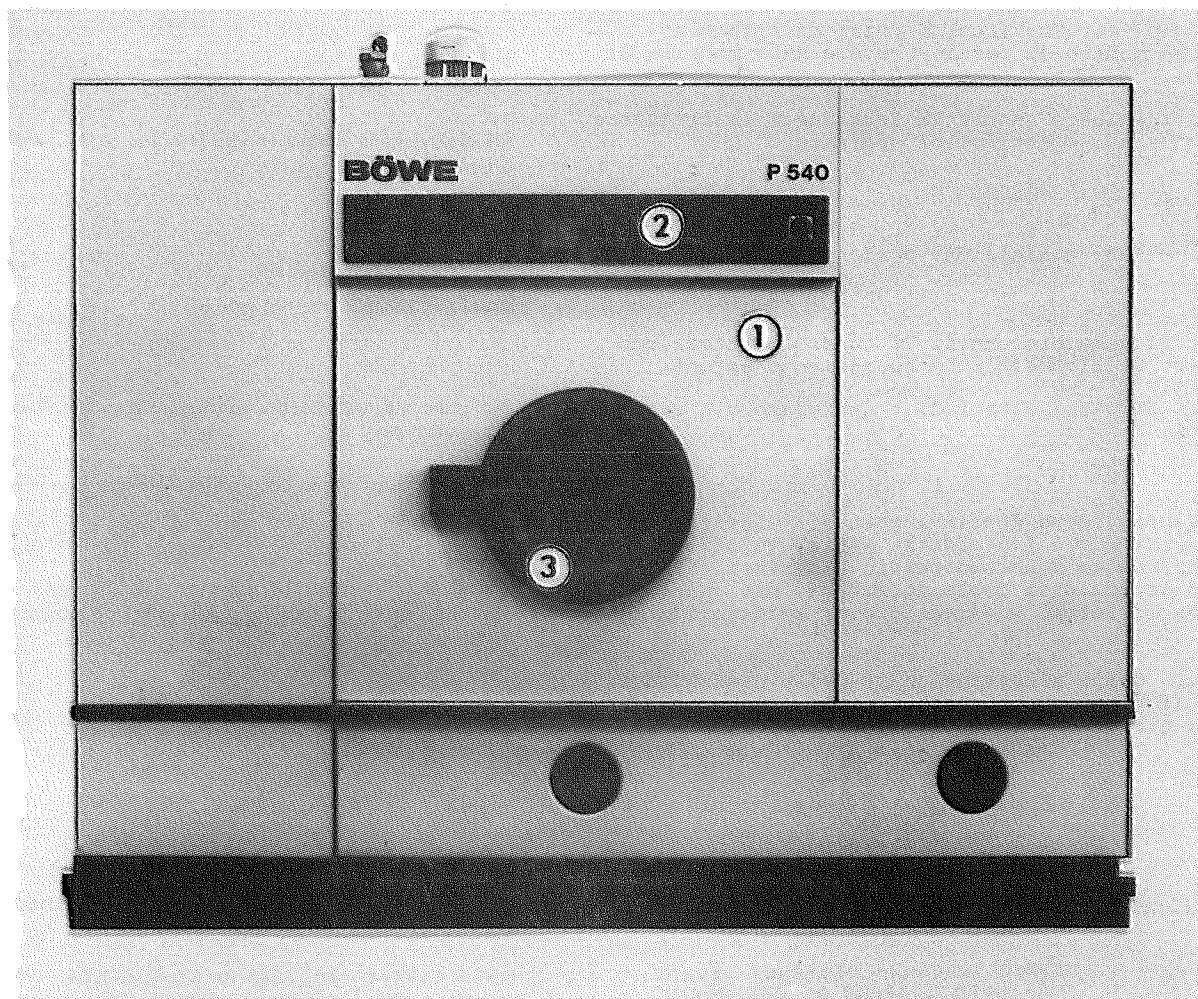

1. VERKLEIDUNG	PANELLING	HABILLAGE	REVESTIMIENTO
2. ELT. STEUERUNG	ELEC. CONTROL	ARMOIRE ELECTRIQUE	MANDO ELECTRICO
3. LADETÜR ELT. STEUERUNG P 546	LOADING DOOR ELEC. CONTROL	HUBLOT ARMOIRE ELECTRIQUE	PUERTA DE CARGA MANDO ELECTRICO
4. TROMMEL MIT GEHÄUSE + TROMMELLAGER	CAGE WITH HOUSING + CAGE BEARING	TAMBOUR AVEC CARTER + PALIER DE TAMBOUR	TAMBOR CON SU CARTER COJINETE TAMBOR
5. TANK	TANK	RESERVOIR	DEPOSITO
6. DESTILLIERBEHÄLTER	STILL	ALAMBIC	DESTILADOR
7. LUFTFÜHRUNGSSCHACHT + KÄLTEAGGREGAT + LADETÜRBELÜFTUNG	RECOVERY SECTION + REFRIGERATION UNIT + LOADING DOOR VENTING	TUNNEL DE RECUPERATION + GROUPE FRIGORIFIQUE + EXTRACTEUR-VENTILTEUR	TUNEL AIRE + GRUPO DE REFRIGERACION + VENTILACION DE LA PUERTA DE CARGA
8. ANTRIEB + ROTATIONS- ANSCHWEMMFILTER + RWP-ÖKO-FILTER	DRIVE + RA PRECOAT FILTER + RWP-ECO-FILTER	MOTEURS + FILTRE ROTATIF A PRECOUCHES + FILTRE-RWP-ÖKO	IMPULSION + FILTRO ROTATIVO DE ALUVION + FILTRO-RWP-ÖKO
9. ENTSORGUNG - EMISSIONSFREI	EMISSIONSFREE REMOVAL OF STILL RESIDUES	EVACUATION DES DECHETS SANS EMISSION	EVACUACIONE DEI RESIDUI SANZA-EMISSION

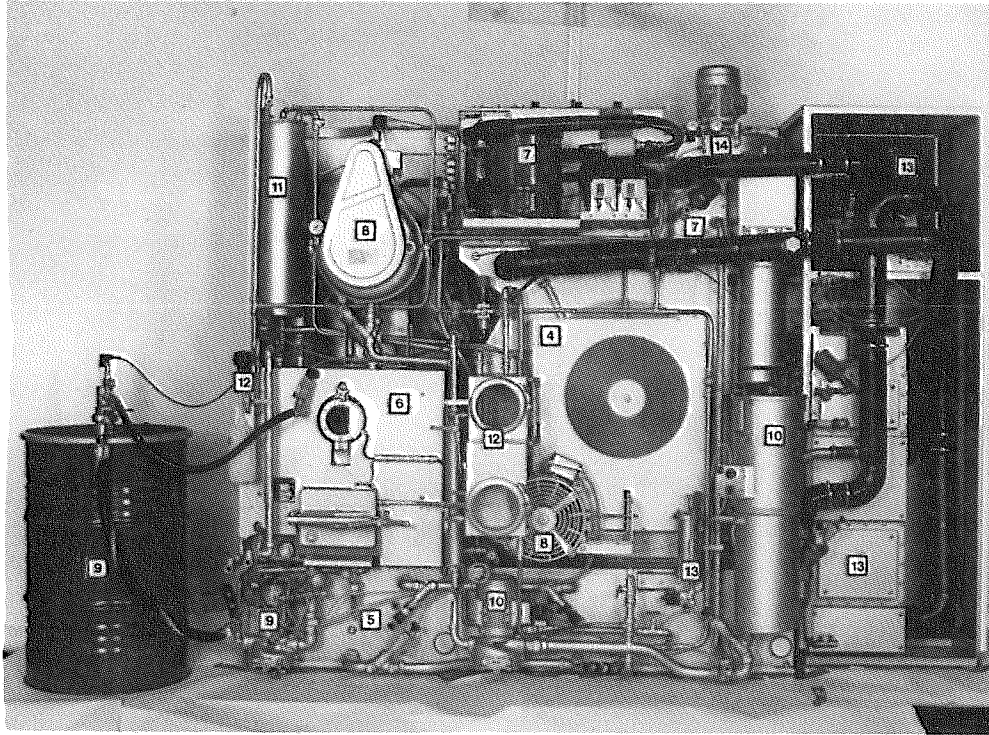

0. NADELFÄNGER + PUMPE	BUTTON TRAP + PUMP	FILTRE A EPINGLES + POMPE	CAZA-BOTONES + BOMBA
1. KONDENSATOR + WÄRMERÜCKFÜHRUNG	CONDENSER HEAT RECYCLING	CONDENSEUR + RECYCLAGE DE LA CHALEUR	CONDENSADOR + RECICLAJE DE CALOR
2. WASSERABSCHIEDER MIT DRYSTAT LÖSEMITTELAUFFÜLLUNG HAND-DOSIERPUMPE (DESTILLATION)	WATER SEPARATOR WITH DRYSTAT SOLVENT FILLING MANUAL DOSING PUMP (STILL)	SEPARATEUR D'EAU AVEC DRYSTAT REMPLEISSAGE SOLVANT POMPE DE DOSAGE MAIN (DISTILLATION)	SEPARADOR AGUA CON DRYSTAT RELLENO DE DISOLVENTE BOMBA DOSIFICADORA A MANO (DESTILADOR)
3. DOSIERGERÄT DG 18 + CONSORBA	DOSING UNIT DG 18 + CONSORBA	DOSEUR DG 18 + CONSORBA	DOSIFICADOR DG 18 + CONSORBA
4. WARTUNGSEINHEIT + KÜHLWASSERREGLER	COMPRESSED AIR MAINTENANCE COOLING WATER REGULATOR	GROUPE D'ENTRETIEN PNEUMATIQUE VANNE THERMOSTATIQUE D'EAU DE REFROIDISSEMENT	UNIDAD DE MANTENIMIENTO DEL SISTEMMA NEUMATICO REGULADOR DEL AGUA REFRIGERANTE
5. VENTILE	VALVES	VANNES	VALVULAS
6. SCHAUGLÄSER	SIGHT-GLASSES	VOYANTS	MIRILLAS
7. VERSCHRAUBUNGEN	SCREWED UNIONS	UNIONS VISSEES	UNIONES
8. ZUBEHÖR	ACCESSORIES	ACCESSOIRES	ACCESORIOS

.....





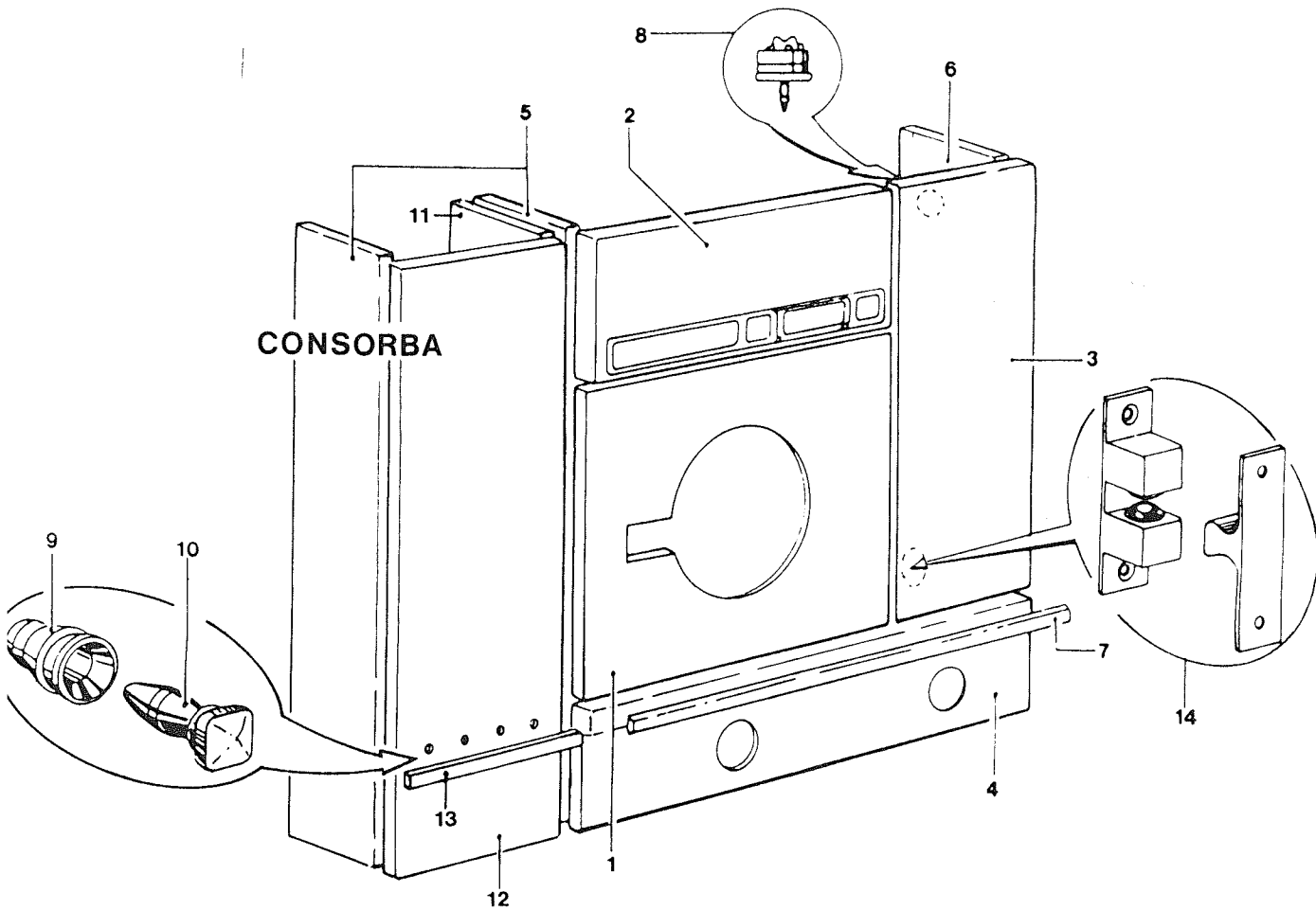

**BESTELLNUMMER**  
**PART NUMBER**

**BENENNUNG**  
**DESIGNATION**

**POS. BESTELLNUMMER**  
**ITEM PART NUMBER**

**BENENNUNG**  
**DESIGNATION**

159154	VORDERWAND FRONT WALL
156182	VERKLEIDUNG OBEN UPPER PANELLING
159151	VERKLEIDUNG VORNE RECHTS FRONT PANELLING RIGHT
68370	TANKVERKLEIDUNG TANK PANELLING
59156	SEITENWAND LINKS SIDE WALL LEFT
59157	SEITENWAND RECHTS SIDE WALL RIGHT
59139	PROFILSTOSSLEISTE PROTECTIVE PROFILE STRIP

8	197137	NIVEAUSCHALTER LEVEL SWITCH
9	014774	ZIERLEISTENHÜLLE DECORATIVE STRIP FUNNEL
10	014773	ZIERLEISTENSTOPFEN DECORATIVE STRIP PIN
11	153307	SEITENWAND RECHTS SIDE WALL RIGHT
12	166214	VORDERWAND FRONT WALL
13	166844	PROFILSTOSSLEISTE PROTECTIVE PROFILE STRIP
14	001972	SCHNAPPVERSCHLUSS SNAP LOCK

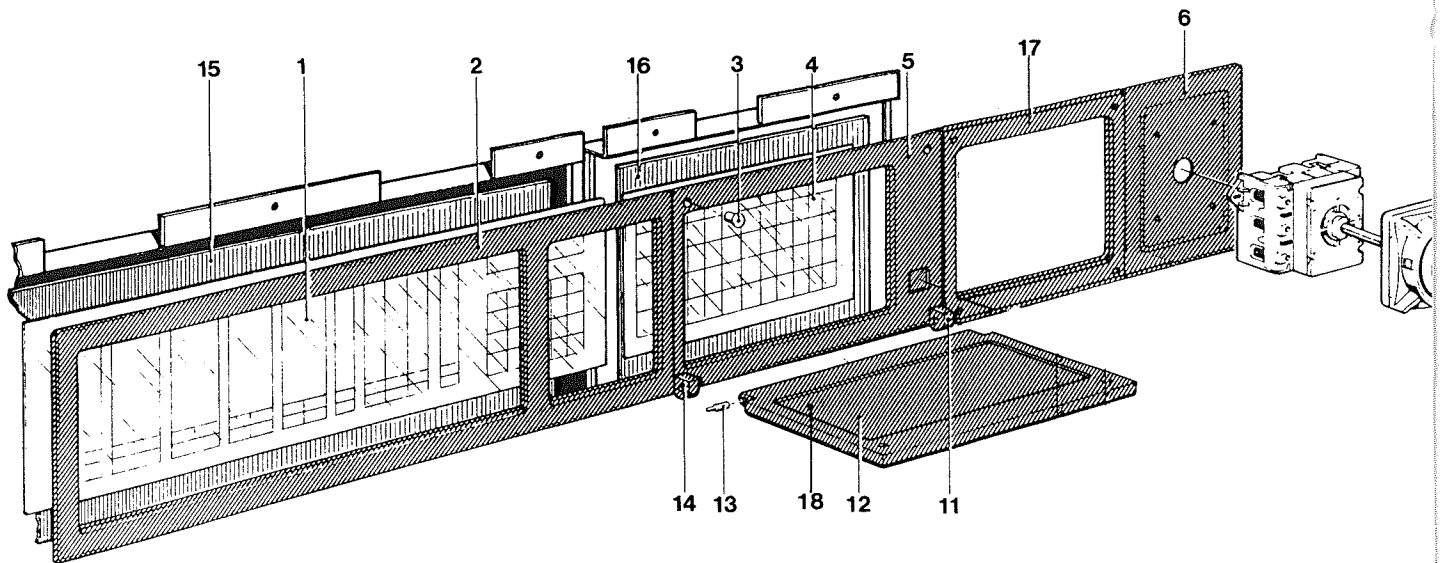

POS. ITEM	BESTELLNUMMER PART NUMBER	BENENNUNG DESIGNATION	POS. ITEM	BESTELLNUMMER PART NUMBER	BENENNUNG DESIGNATION
1	164315	FOLIE BEDIENUNG OPERATING FOIL	12	134804	DECKEL LID
2	134801	BLLENDE TEIL 1 PANEL PART 1	13	134809	WELLE DECKELLAGERUNG LID BEARING SHAFT
3	159823	MAGNETVERSCHLUSS MAGNETIC LOCK	14	134807	SCHARNIER LINKS LEFT HINGE
4	164317	FOLIE PROGRAMMIERUNG PROGRAMMING FOIL	15	163660	BAUTEILETRÄGER BEDIENFELD OPERATING PANEL COMP. CARRIER
5	134802	BLLENDE TEIL 2 PANEL PART 2	16	163668	BAUTEILETRÄGER PROGRAMMTEIL PROGRAM PART COMP. CARRIER
6	134803	BLLENDE TEIL 3 PANEL PART 3	17	134810	BLLENDE TEIL 4 PANEL PART 4
7	026208	HAUPTSCHALTER 80 AMP. MAIN SWITCH	18	164256	SCHILD Progr.-ÜBERSICHT LABEL Progr. REVIEW
11	134808	SCHARNIER RECHTS RIGHT HINGE			

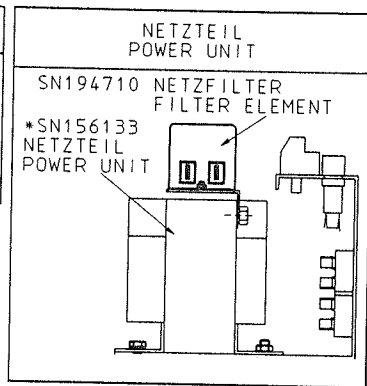
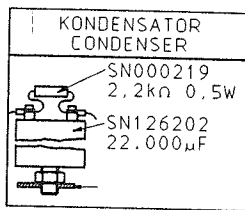
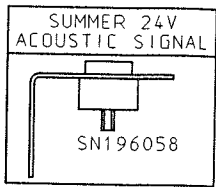

SICHERUNGEN  
FUSE SX20TR

I	SN
0.5	086691
0.63	083610
0.8	002040
1.0	000118
1.25	050026
2.0	000119
2.5	028504
3.15	000121
4.0	000122
6.3	000125
8.0	033053

SI-AUTOMATEN  
CIRCUIT BREAKER

I	SN
3A	001121
6A	195641
10A	000678
16A	000733
20A	195642
25A	195643

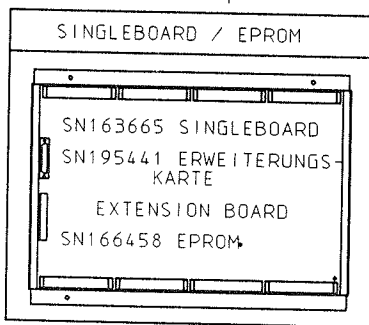
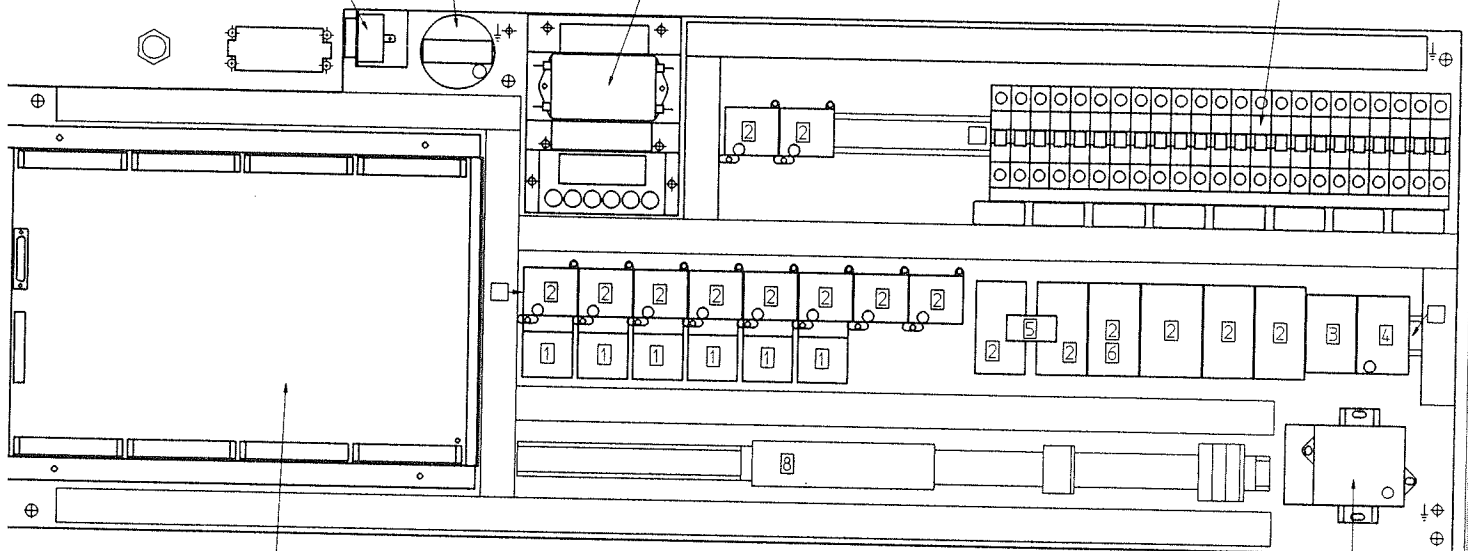

2 SCHUETZE  
CONTACTOR

TYPE	SN
BC6-30-10	159063
BC9-30-10	159064
BC16-30-10	159065
BC25-30-10	163670
KC6-40	161270
VBC6-3002Z	161348

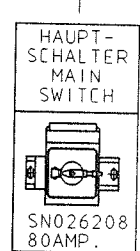
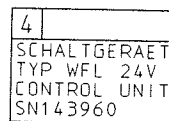
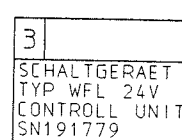
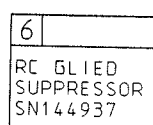
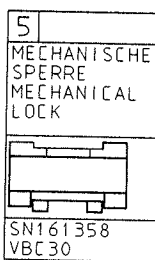

1 THERMOREL.

I (A)	SN
0.14-0.21	160864
0.27-0.4	159955
0.35-0.52	190555
0.42-0.63	159662
0.55-0.83	159418
0.7-1.0	159940
0.9-1.3	159419
1.3-1.8	159941
1.7-2.4	159413
2.1-3.0	159420
2.7-4.0	159414
4.0-6.0	159415
5.2-7.5	159942
7.5-11.0	159428

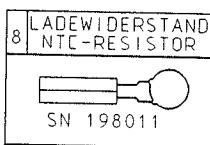

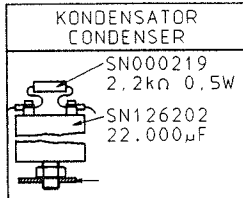
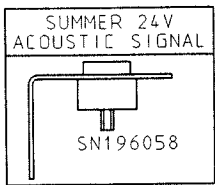

SICHERUNGEN/UL  
FUSE 1/4X11/4"

A	SN
1	163114
2	163206
3.2	163116
4	169728

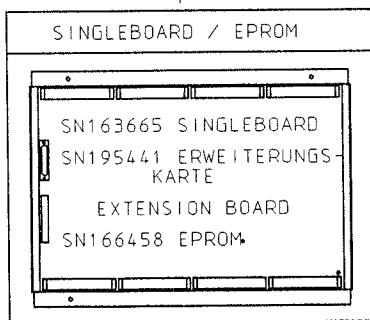
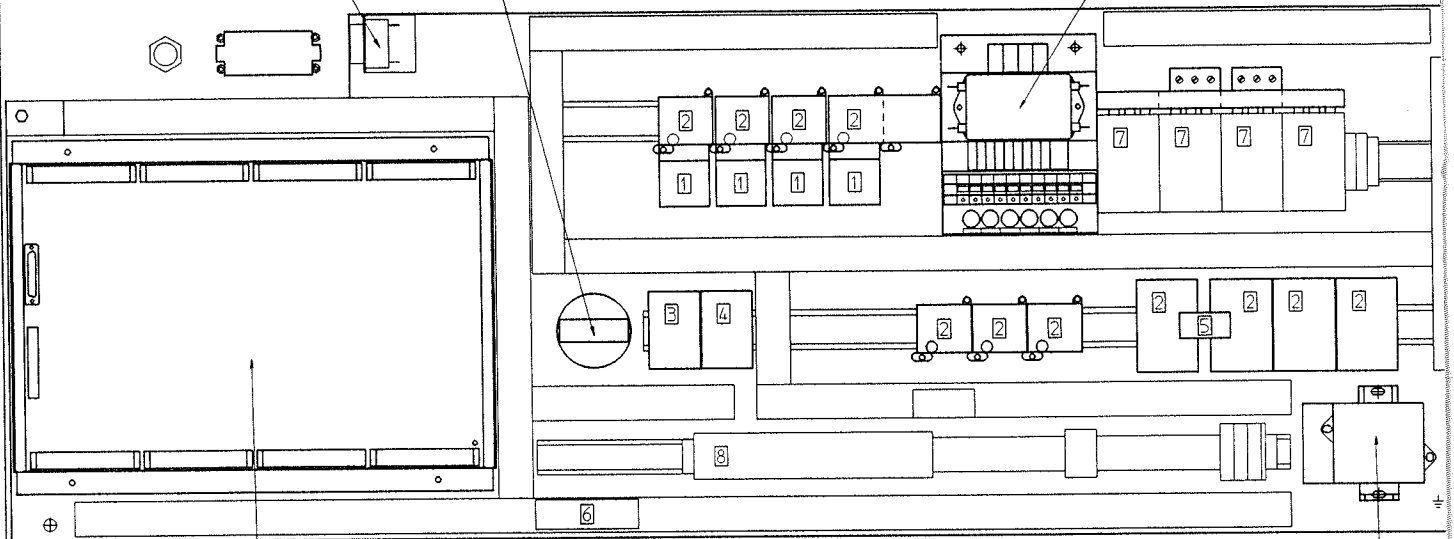
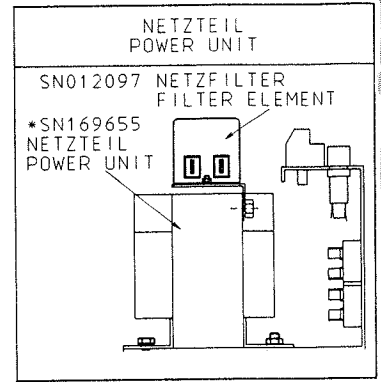

2 SCHUETZE  
CONTACTOR

TYPE	SN
BC6-30-10	159063
BC9-30-10	159064
BC16-30-10	159065
BC25-30-10	163670
KE6-40	161270
VBC6-300Z	161348

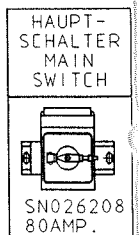
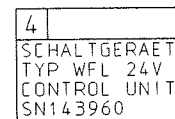
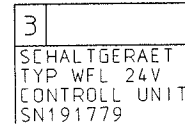
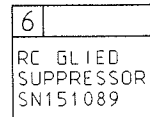
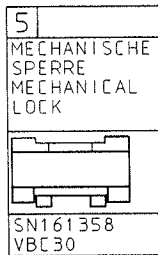

1 THERMOREL.

I (A)	SN
0.14-0.21	160864
0.27-0.4	159955
0.35-0.52	190555
0.42-0.63	159662
0.55-0.83	159418
0.7-1.0	159940
0.9-1.3	159419
1.3-1.8	159941
1.7-2.4	159413
2.1-3.0	159420
2.7-4.0	159414
4.0-6.0	159415
5.2-7.5	159942
7.5-11.0	159428

7 MOTORSCHUTZSCHALTER  
MOTOR CONTROLLER  
M25TM

I	SN
0.6-1.0	190867
1.0-1.6	190868
1.6-2.4	190870
2.4-4.0	190363
4.0-6.0	166943
6.0-10.0	190364
10.0-16.0	169641
16.0-20.0	169642
20.0-25.0	169643

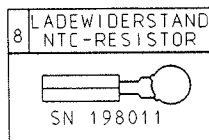

\* 27

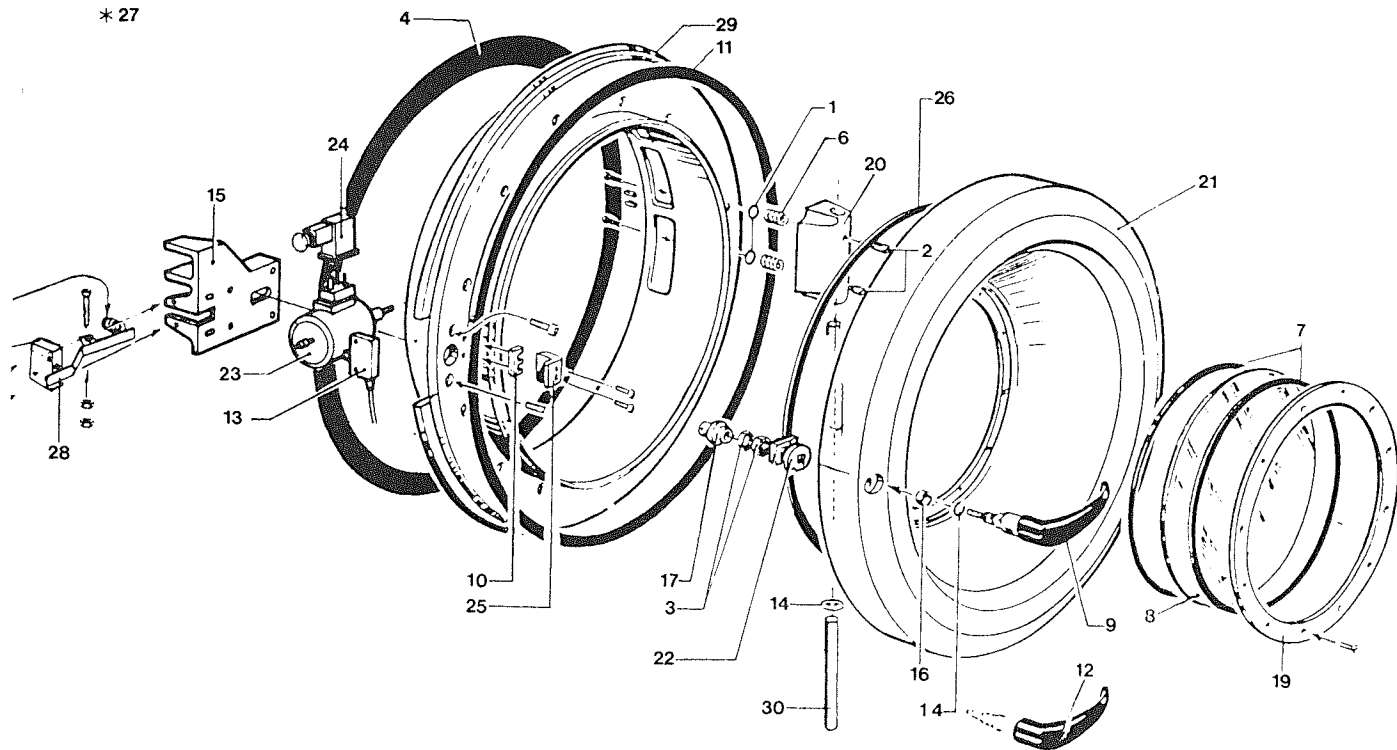

POS. ITEM	BESTELLNUMMER PART NUMBER	BENENNUNG DESIGNATION
1	002412	SCHEIBE 10,5 X 21 - 2 WASHER
2	197353	GEWINDESTIFT 10 X 20 THREADED PIN
3	003793	SECHSKANTMUTTER M 10 HEXAGON NUT
4	015043	FLANSCHDICHTUNG FLANGED GASKET
5	019618	DRUCKFEDER 1,4 X 10,6 X 21 PRESSURE SPRING
6	021983	DRUCKFEDER 3,6 X 10 X 26 PRESSURE SPRING
7	028815	DICHTUNG 3 X 755 GASKET
8	032037	GLASSCHEIBE 246 X 6 GLASS ONLY
9	163542	GRIFF KOMPLETT HANDLE COMPLETE
10	092013	FLACHBAUTEIL FLAT ELEMENT
11	092023	DICHTUNG GASKET
12	161109	HANDSCHUTZ HAND PROTECTOR
13	099550	MIKROSCHALTER MICROSWITCH
14	100680	SCHEIBE WASHER
15	100677	LAGERBOCK BEARING BLOCK

POS. ITEM	BESTELLNUMMER PART NUMBER	BENENNUNG DESIGNATION
16	100682	BUCHSE BUSH
17	100686	MUTTER NUT
18	159391	FLANSCH FLANGE
19	160798	SCHARNIERKLOTZ HINGE BLOCK
20	160797	LADETÜR LOADING DOOR
21	193799	LADETÜR-RIEGEL LOADING DOOR LATCH
22	160755	MAGNETVERRIEGELUNG 24 V MAGNETIC LOCK
23	160885	GERÄTESTECKER COUPLER PLUG
24	143733	ANSCHLAG STOP
25	144292	DICHTUNG GASKET
26	27 * 148907	LADETÜR KOMPLETT LOADING DOOR COMPL.
27	149681	SCHALTHEBEL SWITCH LEVER
28	149863	LADETÜR-FLANSCH LOADING DOOR FLANGE
29	156626	SCHARNIERBOLZEN HINGE BLOCK



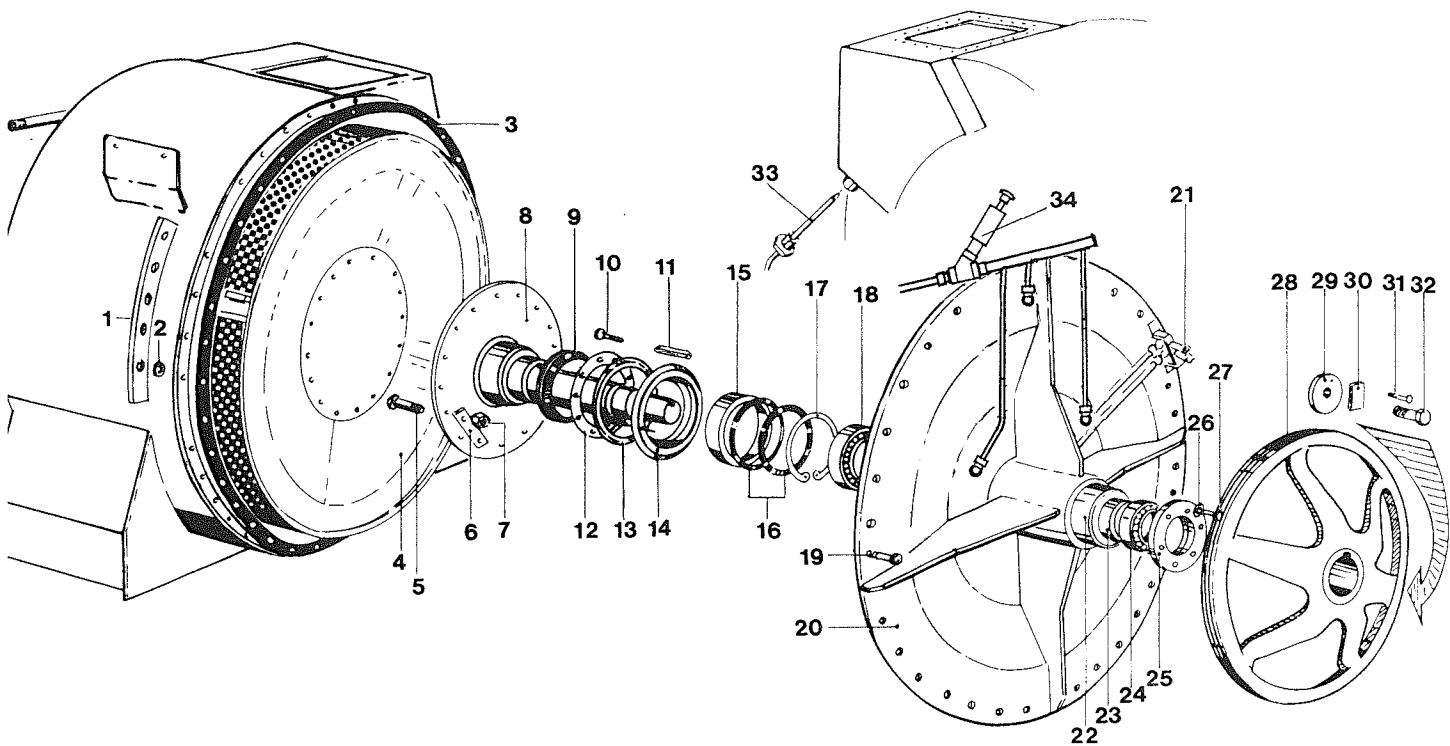

POS. TEM	BESTELLNUMMER PART NUMBER	BENENNUNG DESIGNATION
1	165110	SEGMENT SEGMENT
2	002322	FEDERRING 10 ø SPRING WASHER
3	191636	DICHTUNG 967 X 900 X 3 GASKET
4	155967	TROMMEL CAGE
5	123560	SECHSKANTSCHRAUBE M 12 X 32 HEXAGON HEAD SCREW
6	050390	SICHERUNGSBLECH LOCKING PLATE
7	003823	SECHSKANTMUTTER M 12 HEXAGON NUT
8	205692	FLANSCHWELLE FLANGED SHAFT
9	137075	V-RING V-RING
10	003377	SENKSCHRAUBE 5 X 12 COUNTER SUNK SCREW
11	002520	PASSFEDER 14 X 9 X 54 FITTING KEY
12	133659	SCHEIBE WASHER
13	133444	ABWEISRING DEFLECTO RING
14	133443	ABWEISRING DEFLECTO RING
15	139872	BUCHSE BUSH
16	098845	WELLENDICHTUNG 105 X 130 X 13 GASKET
17	091567	SICHERUNGSRING FÜR BOHRUNG 130 X 4 CIRCLIP

POS. ITEM	BESTELLNUMMER PART NUMBER	BENENNUNG DESIGNATION
18	123562	ZYLINDER ROLLENLAGER 60 X 130 X 31 CYLINDER ROLLER BEARING
19	003153	SECHSKANTSCHRAUBE 10 X 30 HEXAGON HEAD SCREW
20	168674	LAGERFLANSCH FLANGE
21	032790	SCHMIERNIPPEL 1/8" GREASE NIPPLE
22	123440	DISTANZBUCHSE SPACER
23	205694	DISTANZROHR SPACER PIPE
24	123563	RILLENKUGELLAGER GROOVED BALL BEARING
25	123577	TROMMELLAGERDECKEL CAGE BEARING COVER
26	034244	FEDERSCHEIBE SPRING WASHER
27	003141	SECHSKANTSCHRAUBE 8 X 20 HEXAGON HEAD SCREW
28	200396	RIEMENSCHIBE PULLEY
29	115424	SCHEIBE WASHER
30	137416	SICHERUNGSBLECH LOCKING PLATE
31	003127	SECHSKANTSCHRAUBE 6 X 2 HEXAGON HEAD SCREW
32	085788	SECHSKANTSCHRAUBE 12 X 35 HEXAGON HEAD SCREW
33	161162	TEMPERATURSENSOR 40 - 160 °C THERMAL SENSOR
34	109850	SCHRÄGSITZVENTIL SLANTED SEAT VALVE

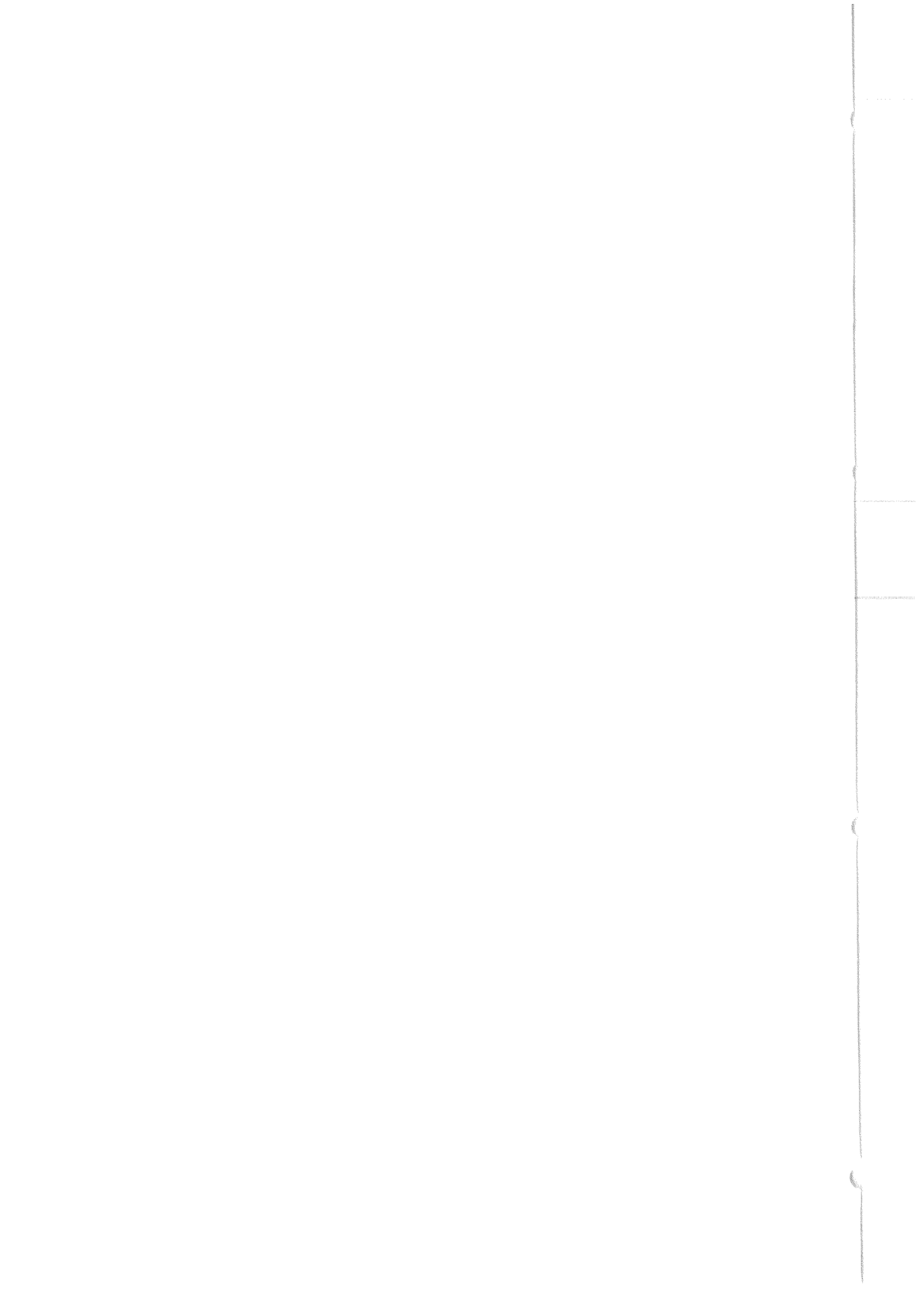



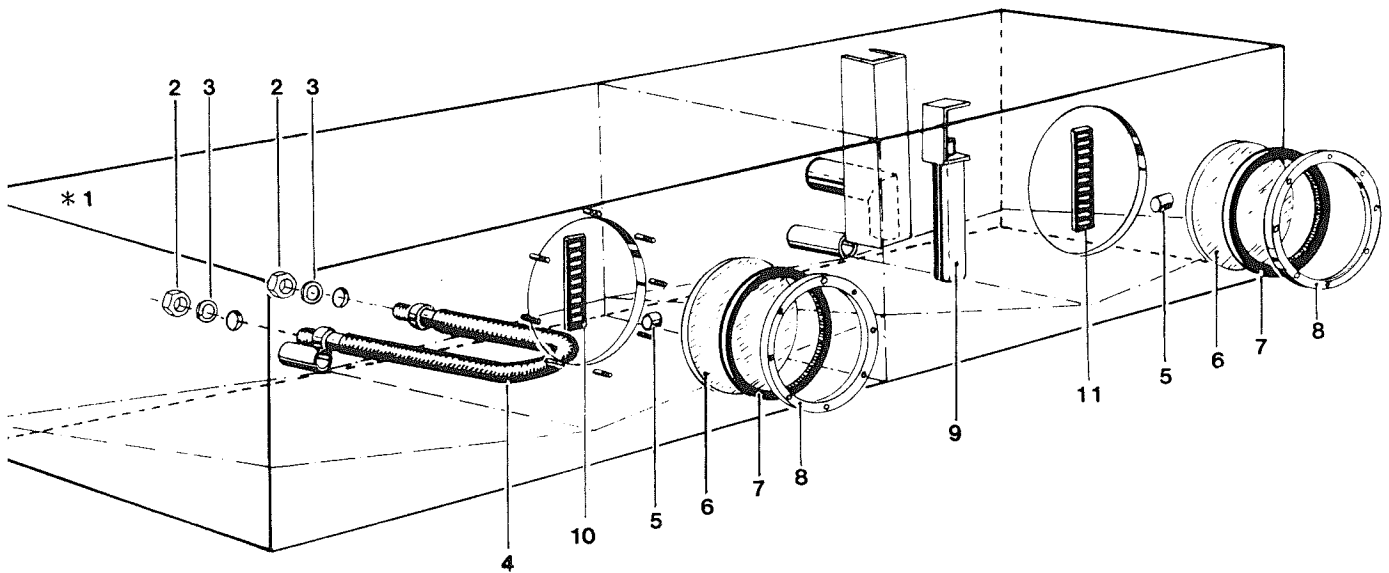

POS. ITEM	BESTELLNUMMER PART NUMBER	BENENNUNG DESIGNATION
1	* 195829	TANK KOMPLETT ET TANK COMPLETE ET
2	016036	SECHSKANTMUTTER 1/2" HEXAGON NUT
3	014075	DICHTSCHEIBE 22 X 34 X 3 GASKET
4	168719	KÜHLSCHLANGE COOLING COIL
5	166126	SCHWIMMER FLOAT
6	144137	GLASSCHEIBE GLASS PANE
7	144097	DICHTUNG GASKET
8	156683	FLANSCH FLANGE
9	054524	ANODE ANODE
10	190308	SKALA REINTANK SCALE CLEANTANK
	190668	SKALA REINTANK P 546 SCALE CLEANTANK
11	190308	SKALA ARBEITSTANK SCALE WORKING TANK
	190669	SKALA ARBEITSTANK P 546 SCALE WORKINGTANK

POS. ITEM	BESTELLNUMMER PART NUMBER	BENENNUNG DESIGNATION	POS. ITEM	BESTELLNUMMER PART NUMBER	BENENNUNG DESIGNATION	POS. ITEM	BESTELLNUMMER PART NUMBER	BENENNUNG DESIGNATION
1	* 196095	DESTILLIERBEHÄLTER OHNE DA/EL-TEILE STILL WITHOUT STEAM /ELEC.-PARTS	26	156780	DECKEL MIT DICHTUNG COVER WITH GASKET	52	197588	HEIZSTAB OHNE ÜBERHITZUNGSSCHUTZ 230 /400 V HEATER ELEMENT WITHOUT OVERH PROTECTION
	* 169669	DESTILLIERBEHÄLTER KOMPL. UL STILL COMPLETE UL		197054	DECKEL MIT DICHTUNG OHNE 1" BOHRUNG COVER WITH GASKET WITHOUT 1" HOLE	54	198990	HEIZSTAB OHNE ÜBERHITZUNGSSCHUTZ 230 /400 V, HEATER ELEMENT WITHOUT OVERH PROTECTION
2	031940	SCHMUTZFÄNGER 1/2" STRAINER		166992	DECKEL MIT DICHTUNG P 546 COVER WITH GASKET	56	163698	TEMPERATURSENSOR 40 - 180 °C THERMAL SENSOR
3	031887	STEUERVENTIL FÜR DAMPF CONTROL VALVE FOR STEAM	27	002553	BOLZEN OHNE KOPF HEADLESS BOLT	57	169930	ENDSCHALTER LIMIT SWITCH
4	031892	DURCHGANGSVENTIL FÜR DAMPF TROUGH-WAY VALVE FOR STEAM	28	003686	AUGENSCHRAUBE EYE SCREW	58	128759	VERSCHRAUBUNG UNION
5	125677	RÜCKSCHLAGVENTIL 1/2" CHECK VALVE	29	002418	SCHEIBE DISC	59	128762	VERSCHRAUBUNG T UNION T-PIECE
6	002547	BOLZEN OHNE KOPF 12 X 50 X 42 HEADLESS BOLT	30	163695	FLÜGELMUTTER M 16 WING NUT	60	002918	DOPPELNIPPEL DOUBLE NIPPLE
7	002547	BOLZEN OHNE KOPF 12 X 80 X 70 HEADLESS BOLT	31	156745	HEBEL LEVER	61	195368	VERBINDUNG CONNECTION
8	003681	AUGENSCHRAUBE 12 X 80 EYE SCREW	32	089957	KUGELHAHN 1" BALL-COCK	62	058053	NIPPEL A/I RED. NIPPLE REDUCTION
9	003670	AUGENSCHRAUBE 12 X 60 EYE SCREW	33	166555	HEIZROHR DAMPF HEATING PIPE STEAM	63	058062	VERSCHRAUBUNG UNION
10	123516	DICHTUNG 118 X 142 X 12 GASKET	34	127397	DICHTUNG 50 X 70 X 3 GASKET			
10	159371	DICHTUNG P 546 GASKET	35	109360	KONDENSATABLEITER STEAM TRAP			
11	123354	SCHAUGLASRAHMEN SIGHT-GLASS FRAME	36	031913	RÜCKSCHLAGKLAPPE CHECK VALVE			
12	002417	SCHEIBE DISC	37	196048	SICHERUNGSMUTTER LOCK NUT			
13	002495	KREUZGRIFF CROSS NUT	37a	168635	FLACHMUTTER M 16 HEXAGON NUT			
14	002415	SCHEIBE DISC	38	031998	PNEUMATIKSCHALTER PNEUMATIC SWITCH			
15	003821	SECHSKANTMUTTER M 12 HEXAGON NUT	39	148031	SECHSKANTMUTTER 3/8" HEXAGON NUT			
16	159372	DICHTUNG U-PROFIL 119 X 123 X 9 GASKET	40	148032	DICHTUNG 8,2 X 12 X 1,5 GASKET			
17	021616	GLASSCHEIBE GLASS	41	125688	EDELSTAHLSONDE STAINLESS STEEL PROBE			
18	133922	FLANSCH FLANGE	42	127546	MANOMETER PRESSURE GAUGE			
19	074407	ZYLINDERSCHRAUBE 6 X 20 CYLINDRICAL HEAD SCREW	43	128723	SICHERHEITSVENTIL SAFETY VALVE			
20	155793	LAMPE 24 V LAMP	44	128965	ROHR TUBE			
21	155792	LAMPENHALTER LAMP HOLDER	45	151060	SPINDEL MIT HANDRAD SPINDLE WITH HANDWHEEL			
22	159146	HAUBE COVER	46	127398	GEWINDEFANSCH THREADED FLANGE			
23	002545	BOLZEN OHNE KOPF 12 X 55 X 44 HEADLESS BOLT	47	128758	DICHTUNG 48 X 55 X 2 GASKET			
24	012025	DICHTUNG 197 X 267 X 15 GASKET	48	198988	HEIZSTAB MIT ÜBERHITZUNGSSCHUTZ 230 /400 V, 8 KW HEATER ELEMENT WITH OVERHEATING PROTECTION			
25	051784	BOLZEN OHNE KOPF 12 X 70 X 60 HEADLESS BOLT						

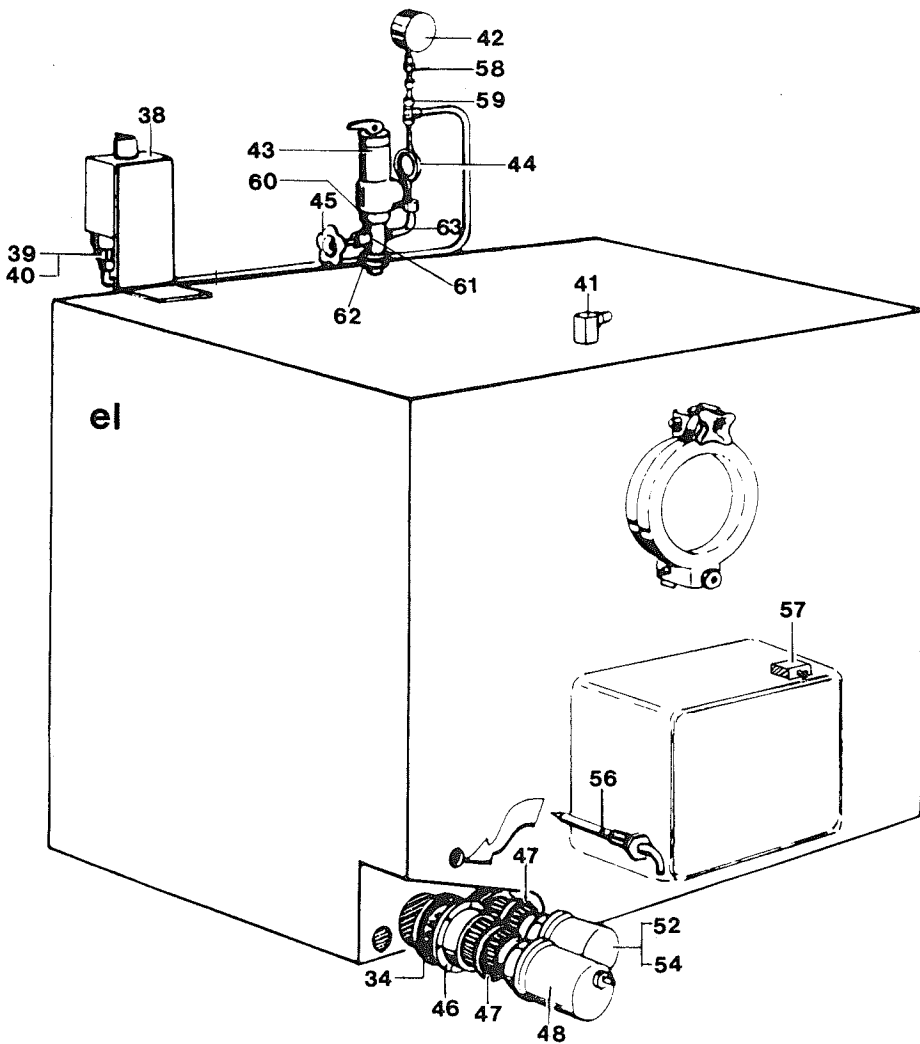
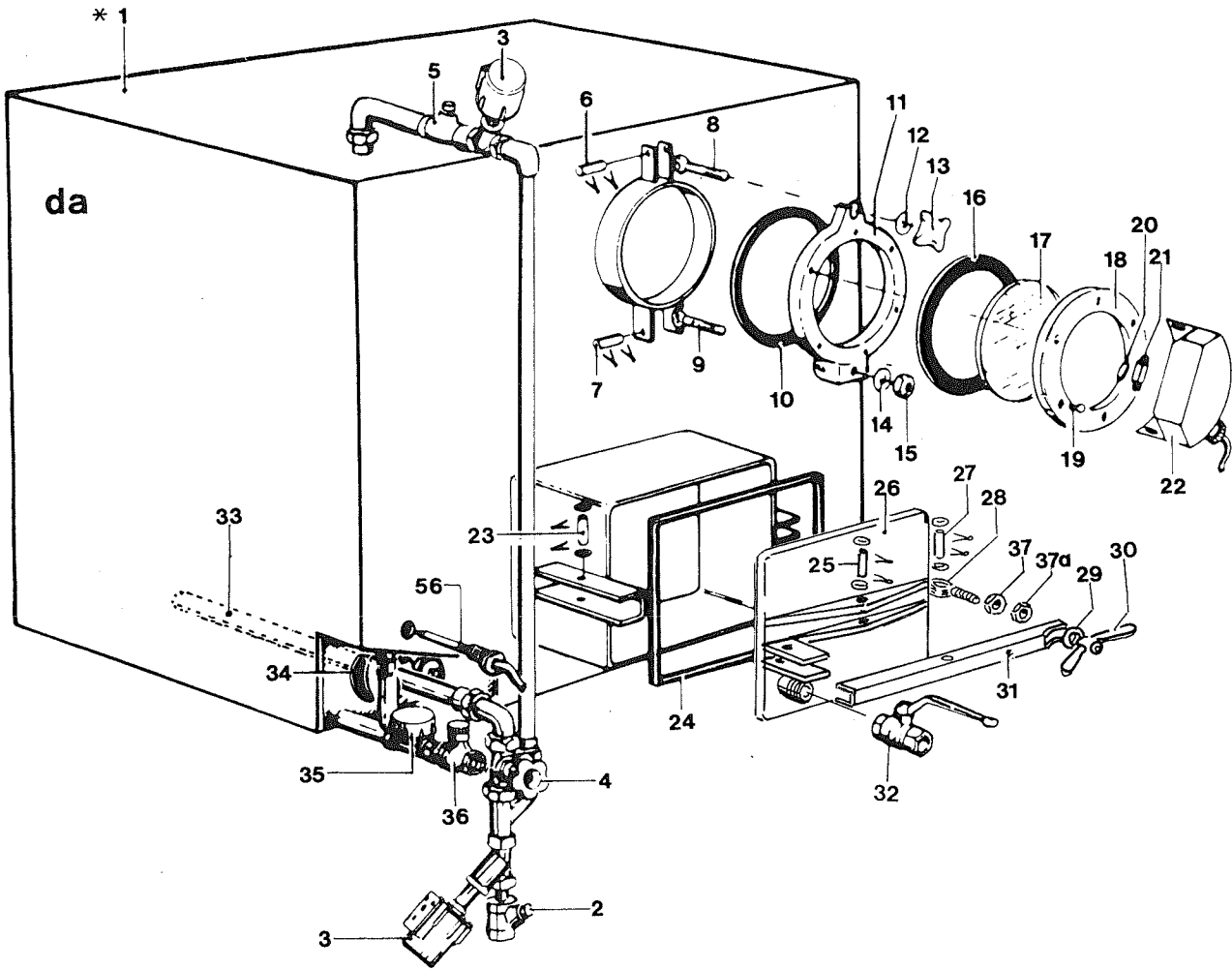

POS. ITEM	BESTELLNUMMER PART NUMBER	BENENNUNG DESIGNATION	POS. ITEM	BESTELLNUMMER PART NUMBER	BENENNUNG DESIGNATION	POS. ITEM	BESTELLNUMMER PART NUMBER	BENENNUNG DESIGNATION
1	* 190903	LUFTSCHACHT MIT DICHTUNGEN RECOVERY SECTION WITH GASKET	28	014075	DICHTSCHEIBE 22 X 34 X 3 GASKET	* 169673		KÄLTEAGGREGAT KOMPL 220 V, 60 HZ REFRIGERATION UNIT CO
	* 196536	LUFTSCHACHT KOMPLETT MIT KÄLTEAGGREGAT 380 - 415 V, 50 HZ RECOVERY SECTION COMPL. WITH REFRIGERATION UNIT	29	168394	DECKEL COVER	57	200290	EXPANSIONSVENTIL TEX2 EXPANSION VALVE
	* 196537	LUFTSCHACHT KOMPL. MIT KÄLTEAGGREGAT 220 V, 50 HZ RECOVERY SECTION COMPL. WITH REFRIGERATION UNIT	30	016036	SECHSKANTMUTTER 1/2" HEXAGON NUT	58	203974	SHELLE CLAMP
2	161592	DECKEL COVER	31	031887	STEUERVENTIL FÜR DAMPF 1/2" CONTROL VALVE FOR STEAM	59	144737	ABSPERRVENTIL CHECK VALVE
3	161591	DICHTUNG GASKET	32	031940	SCHMUTZFÄNGER 1/2" STRAINER	60	159361	SCHAUGGLAS SIGHT-GLASS
4	159451	DICHTUNG GASKET	33	159178	KLAPPE DAMPER	61	200294	TROCKNER DRIER
5	159796	DICHTUNG GASKET	34	159467	DISTANZROHR DISTANCE SPACER	62	143174	SAMMLER COLLECTOR
6	164122	DICHTUNG GASKET	35	087440	BUCHSE BUSH		190713	SAMMLER P 546 COLLECTOR
7	166351	SICHERHEITSVENTIL 0,3 BAR SAFETY VALVE	36	144932	DICHTUNG GASKET	63	126225	KONDENSATOR CONDENSER
8	200609	TEMPERATURSENSOR THERMAL SENSOR	37	010484	WELLENDICHTUNG 15 X 24 X 7 SHAFT GASKET	64	125739	KÜHLWASSERREGLER 3/4 COOLING WATER REGUL
9	198982	LÜFTERMOTOR 400 V, 50 HZ FAN MOTOR	38	100872	DROSSELVENTIL THROTTLE VALVE	65	031940	SCHMUTZFÄNGER 1/2" STRAINER
10	198981	LÜFTERMOTOR 230 V, 50 HZ FAN MOTOR	39	121261	3-WEGEVENTIL 3-WAY VALVE	66	116962	DURCHGANGSVENTIL TROUGH-WAY VALVE
	169612	LÜFTERMOTOR 220 V, 60 HZ FAN MOTOR	40	031863	PRESSLUFTZYLINDER PNEUMATIC RAM	67	164125	VENTILATOR FAN
11	700203	DICHTUNG GASKET	41	161589	LUFTVORWÄRMER AIR PREHEATER	68	163546	DICHTUNG GASKET
12	700205	FLANSCH-LATERNE FLANGE	42	148589	RUNDDICHTUNG 28 X 5,5 GASKET	69	190774	BELÜFTUNGSROHR VENTING PIPE
13	032790	SCHMIERNIPPEL-KEGEL GREASE NIPPLE	43	161590	KÜHLREGISTER COOLER	69a	169700	FLANSCHROHR FLANGE PIPE
14	010486	WELLENDICHTUNG 22 X 35 X 7 SHAFT GASKET	44	148588	RUNDDICHTUNG GASKET	70	161310	SCHRÄGSITZVENTIL 2" SLANTED SEAT VALVE
16	190303	SCHEIBE 8,4 X 25 X 4 DISC	45	149456	DICHTUNG 36 X 38 X 1,6 GASKET	71	163835	GERÄTESTECKER RECEPTACLE
17	002376	SICHERUNGSBLECH LOCKING PLATE	46	144738	ABSPERRVENTIL V04 CHECK VALVE	72	031987	VAKUUM MANOMETER VACUUM PRESSURE GAU
18	003200	SECHSKANTSCHRAUBE M 8 X 25 HEXAGON HEAD SCREW	47	151044	DICHTUNG 22,2 X 25,4 X 1,6 GASKET	73	163698	TEMPERATURSENSOR 40 THERMAL SENSOR
19	198991	LÜFTERMOTOR KOMPLETT 230 V, 50 HZ FAN MOTOR COMPL.	48	159401	DICHTRING GASKET	74	161312	DICHTUNG GASKET
20	198992	LÜFTERMOTOR KOMPLETT 400 V, 50 HZ FAN MOTOR COMPL.	49	144739	ABSPERRVENTIL V06 CHECK VALVE	75	166166	FLANSCHROHR FLANGE-PIPE
	166973	LÜFTERMOTOR KOMPLETT 220 V, 60 HZ FAN	50	126900	VERDICHTER 380 - 415 V, 50 HZ COMPRESSOR	76	121261	VENTIL PNEUMATIK PNEUMATIC VALVE
21	700204	FLANSCHRING FLANGE RING	51	126899	VERDICHTER 230 V, 50 HZ COMPRESSOR	77	168713	PRESSLUFTZYLINDER PNEUMATIC RAM
22	125878	LÜFTERRAD FAN WHEEL	51	200616	VERDICHTER 230 V, 60 HZ COMPRESSOR	78	209609	DECKEL COVER
	127724	LÜFTERRAD 220 V, 60 HZ FAN WHEEL	52	115646	PRESSOSTAT 6 - 32 BAR PRESSURE CONTROL SWITCH	79	168866	DICHTUNG GASKET
23	198986	HEIZREGISTER 400 V, 6 KW HEATER		157867	PRESSOSTAT P 546 PRESSURE CONTROL SWITCH	80	090956	MUTTER NUT
25	168395	DICHTUNG GASKET	53	115648	PRESSOSTAT 0,2 - 7,5 BAR PRESSURE CONTROL SWITCH	81	168862	TELLER DISC
26	090797	KONTAKT-THERMOMETER 0 - 250 °C TEMPERATURE CONTROL GAUGE		203972	PRESSOSTAT P 546 UL PRESSURE CONTROL SWITCH	82	168863	DICHTUNG GASKET
27	168771	HEIZREGISTER DAMPF HEATER STEAM	54	159475	EINSCHRAUBVENTIL SCREWED VALVE	83	168861	TELLER DISC
			55	190342	DÜSE NR. 6 NOZZLE NO. 6	84	090952	DICHTRING SEAL
			56	* 196527	KÄLTEAGGREGAT KOMPLETT 380 - 415 V, 50 HZ REFRIGERATION UNIT COMPL.			
				* 196528	KÄLTEAGGREGAT KOMPLETT 230 V, 50 HZ REFRIGERATION UNIT COMPL.			

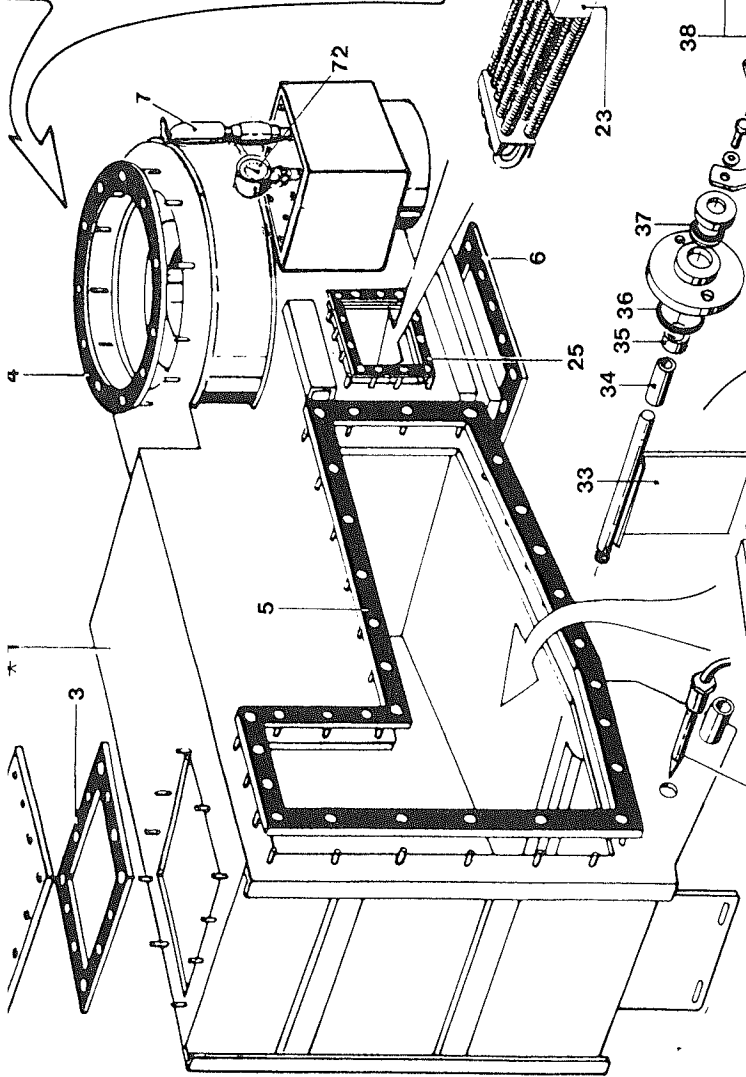
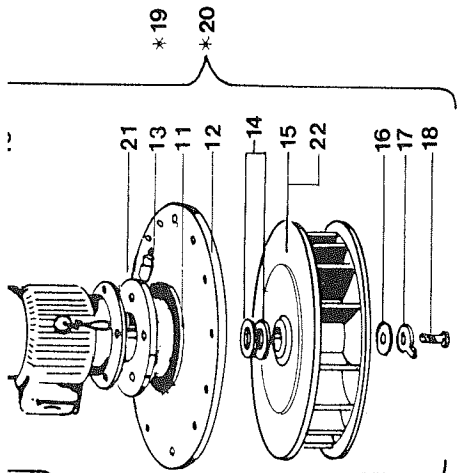
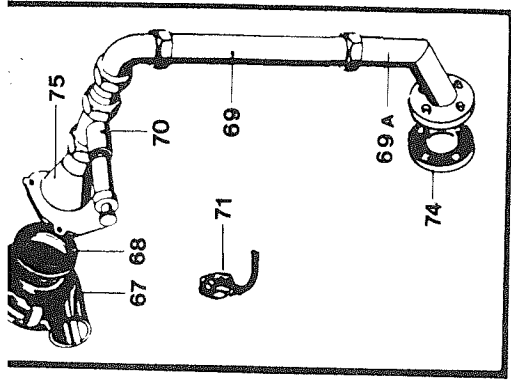

KÄLTEMITTEL R 22  
REFRIGERATION AID R 22

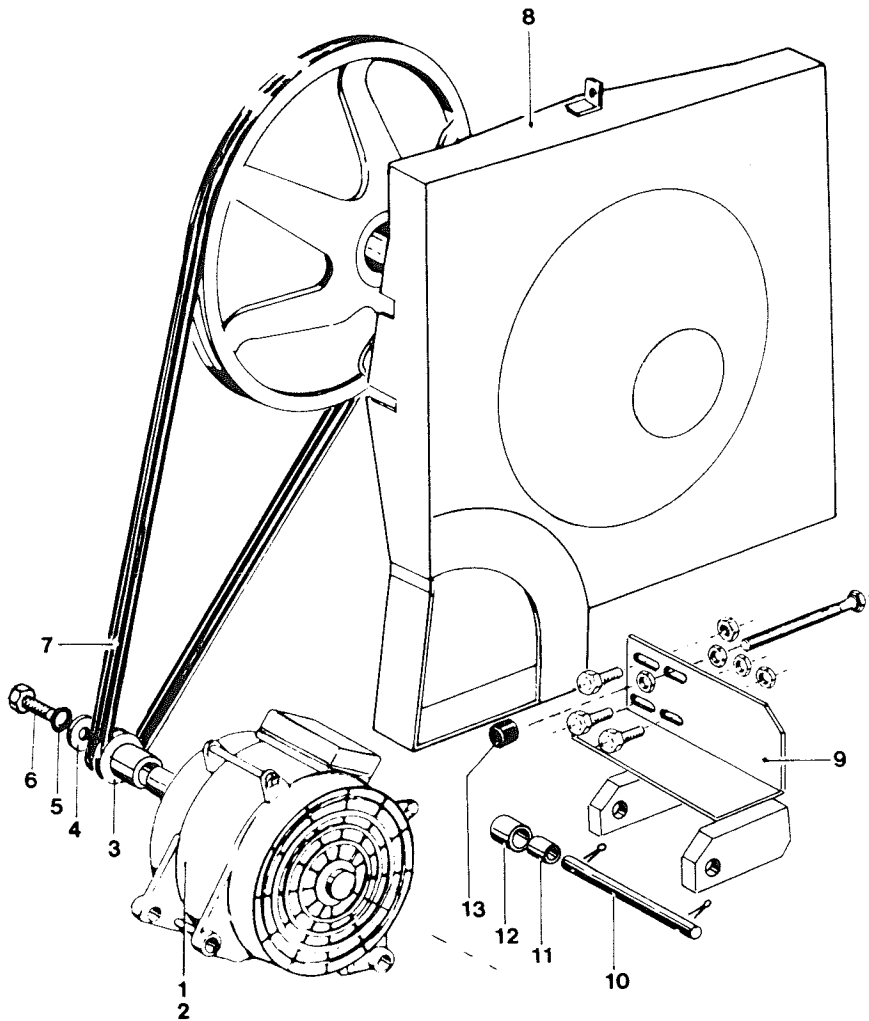

POS. ITEM	BESTELLNUMMER PART NUMBER	BENENNUNG DESIGNATION
1	198980	ANTRIEBSMOTOR 230 /400 V, 50 HZ DRIVE MOTOR
2	127964	ANTRIEBSMOTOR 220 V, 60 HZ DRIVE MOTOR
3	128497	KEILRIEMENSCHLEIBE V BELT PULLEY
4	015262	SCHEIBE WASHER
5	001217	ZAHNSCHLEIBE TOOTHED WASHER
6	003139	SECHSKANTSCHRAUBE HEXAGON HEAD SCREW
7	160836	KEILRIEMEN (3 STÜCK) V BELT (3 PCE.)

POS. ITEM	BESTELLNUMMER PART NUMBER	BENENNUNG DESIGNATION
8	168841	RIEMENSCHUTZ BELT GUARD
9	168837	KONSOLE CONSOLE
10	163412	BOLZEN BOLT
11	151054	METALLGUMMIBUCHSE BUSH
12	153375	BUCHSE BUSH
13	169614	PUFFER BUFFER

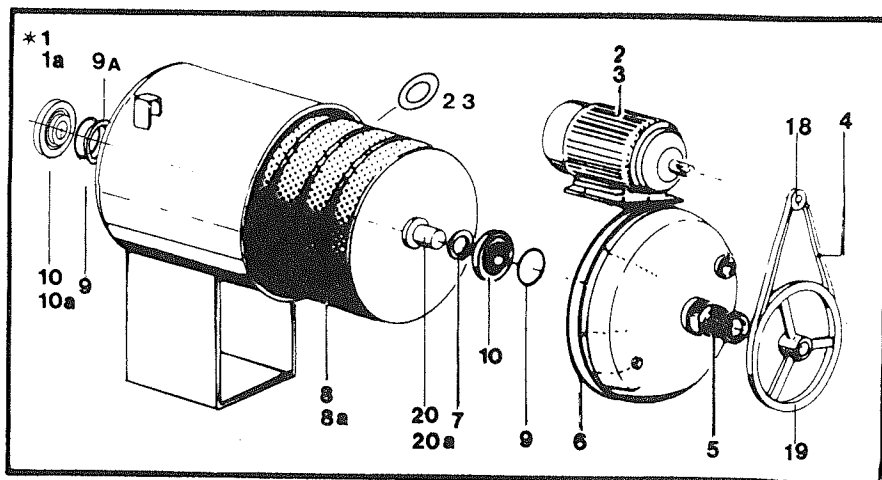
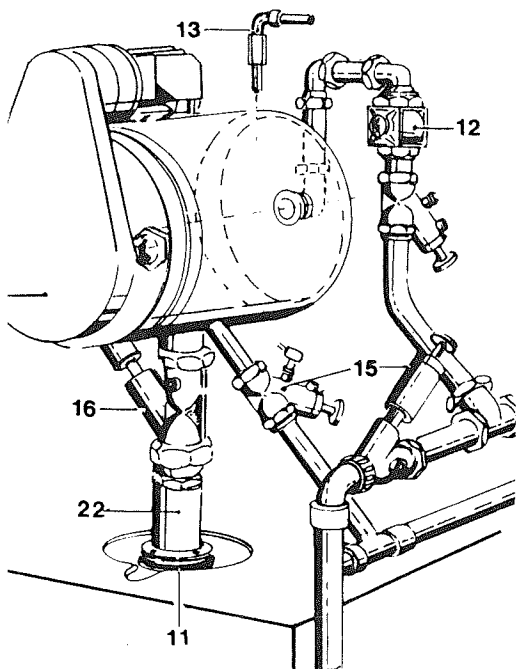

POS. BESTELLNUMMER  
ITEM PART NUMBER

BENENNUNG  
DESIGNATION

1	* 198974	ROTATIONSANSCHWEMMFILTER MIT 30 SCHEIBEN 230 /400 V ROTATIONAL-WHIRLING FILTER WITH 30 DISC
	* 169618	ROTATIONSANSCHWEMMFILTER MIT 30 SCHEIBEN 220 V, 60 HZ ROTATIONAL-WHIRLING FILTER WITH 30 DISC
1a	* 198979	RWP-ÖKO-FILTER (ANSCHWEMMFREI) 30 SCHEIBEN 230 /400 V, 50 HZ RWP-ECO-FILTER (WITHOUT FILTERPOWDER) WITH 30 DISC
	* 032033	RWP-ÖKO-FILTER (ANSCHWEMMFREI) 30 SCHEIBEN 220 V, 60 HZ RWP-ECO-FILTER (WITHOUT FILTERPOWDER) WITH 30 DISC
2	198995	MOTOR 230 /400 V, 50 HZ MOTOR
3	169629	MOTOR 220 V, 60 HZ MOTOR
4	169983	KEILRIEMEN (1 STÜCK) V-BELT (1 PCE.)
5	169984	RILLENKUGELLAGER GROOVED BEARING
6	169985	DICHTUNG GASKET
7	169987	WELLENDICHTUNG GASKET
8	161237	RA-FILTERSCHEIBE (30 STÜCK) FILTER WASHER
	014329	AT-FILTERSCHEIBE RA-FILTER EXCH.-FILTER WASHER
	008299	ÖKO-FILTERSCHEIBE (30 STÜCK) FILTER WASHER
	198520	AT-FILTERSCHEIBE RWP-FILTER EXCH.-FILTER WASHER
9	169986	O-RING O-RING

POS. BESTELLNUMMER  
ITEM PART NUMBER

BENENNUNG  
DESIGNATION

9a	190849	DICHTUNG GASKET
10	169712	BUCHSE BUSH
10a	191375	BUCHSE BUSH
11	163832	DICHTUNG GASKET
12	163605	DURCHGANGSSCHAUGLAS 1 1/4" TUBULAR SIGHT-GLASS
13	134723	RÜCKSCHLAGVENTIL CHECK VALVE
14	031992	MANOMETER 0 - 6 BAR PRESSURE GAUGE
15	139407	SCHRÄGSITZVENTIL 1" SLANTED SEAT VALVE
16	161310	SCHRÄGSITZVENTIL 2" SLANTED SEAT VALVE
18	190854	RIEMENSCHIBE KEIL 1 RILLIG V BELT PULLEY
19	190855	RIEMENSCHIBE KEIL 1 RILLIG V BELT PULLEY
20	191379	WELLE FILTER SHAFT FILTER
20a	191770	WELLE FILTER SHAFT FILTER
21	193802	RIEMENSCHUTZ BELT GUARD
22	161320	FILTER-ABLASSROHR FILTER-OUTLET TUBE
23	197352	FILTERSCHEIBENABDICHTUNG FILTER WASHER GASKET





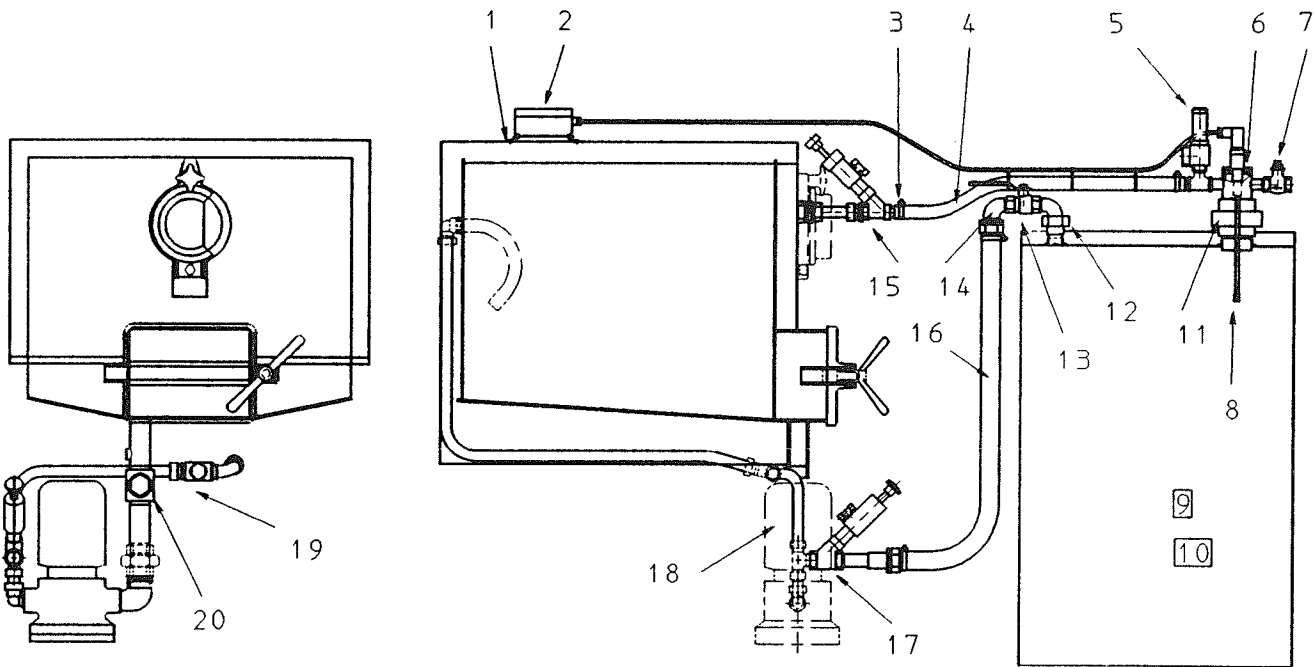

POS. BESTELLNUMMER W PART NUMBER	BENENNUNG DESIGNATION	POS. BESTELLNUMMER ITEM PART NUMBER	BENENNUNG DESIGNATION
126843	HALTEBLECH HOLDING METAL	12 127971	WINKELVERSCHraubUNG A/A ANGLE UNION
159058	KAPAZITIVSCHALTGERÄT CAPACITIVE CONTROL GEAR	13 116328	KUGELHAHN BALL-COCK VALVE
129991	SHELLE CLAMP	14 002782	WINKEL A/A ELBOW
032592	PERBUNAN N SCHLAUCH HOSE	15 013543	SCHRÄGSITZVENTIL SLANTED SEAT VALVE
166351	SICHERHEITSVENTIL 0,3 BAR SAFETY VALVE	16 197846	SCHLAUCH, 1 M HOSE
025237	ENTLÜFTUNGSROHRLEITUNG TUBE (AERATING)	197847	SCHLAUCH, 2 M HOSE
031917	RÜCKSCHLAGVENTIL 1/2" 0,1 BAR CHECK VALVE	17 109850	SCHRÄGSITZVENTIL 3/4" SLANTED SEAT VALVE
144922	NIVEAUSONDE LEVEL SENSOR	18 209373	PUMPE MIT MOTOR, 190 - 440 V, 50 HZ PUMP
196165	DB ENTSORGUNGSFASS 100 L BARREL	123588	PUMPE MIT MOTOR, 208 - 440 V, 60 HZ PUMP
196166	DB ENTSORGUNGSFASS 200 L BARREL	19 031874	SCHNELLSCHL.-SCHIEBER LEVER GATE VALVE
002902	VERSCHRAUBUNG I/A-KOND.DIC UNION	20 031872	SCHNELLSCHL.-SCHIEBER LEVER GATE VALVE

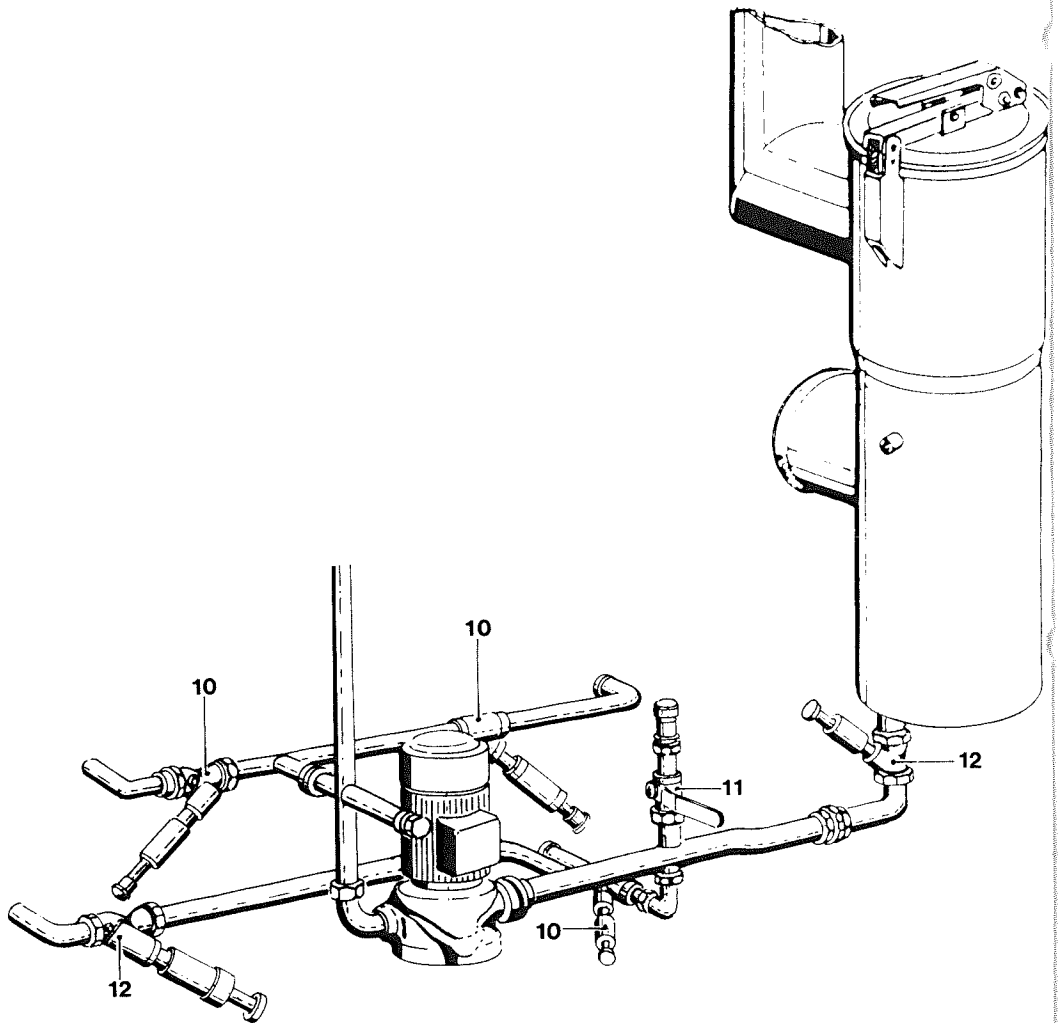
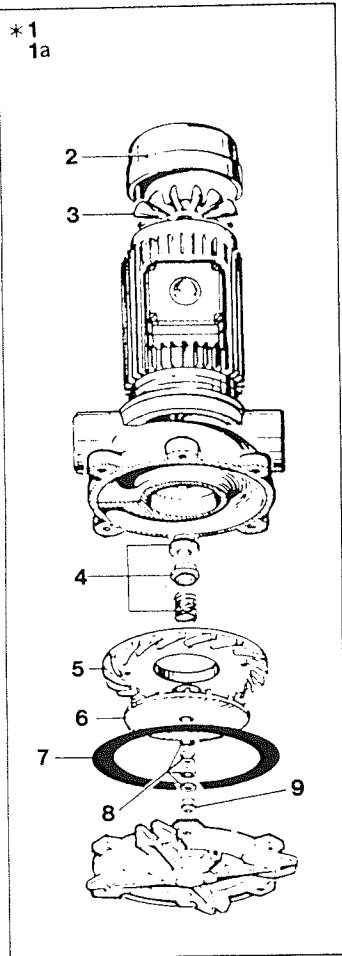

POS. ITEM	BESTELLNUMMER PART NUMBER	BENENNUNG DESIGNATION
1	139424	PUMPE MIT MOTOR 190 - 440 V 50 HZ PUMP WITH MOTOR
1a	139425	PUMPE MIT MOTOR 190 - 440 V 60 HZ PUMP WITH MOTOR
2	093605	SCHUTZHAUBE HOAD
3	093601	LÜFTERRAD FAN WHEEL
4	156077	GLEITRINGDICHTUNG KOMPL. COUNTER RING COMPL.
5	123540	LEITRING GUIDE RING
5a	125705	LEITRING 220 V 60 HZ GUIDE RING
6	143080	PUMPENRAD PUMP IMPELLOR
6a	143081	PUMPENRAD 220 V 60 HZ PUMP IMPELLOR

POS. ITEM	BESTELLNUMMER PART NUMBER	BENENNUNG DESIGNATION
7	073039	GEHÄUSEDICHTUNG GASKET
8	055067	VERBINDUNG SPANNELEMENT CONNECTION CLAMP SLEEVE
9	052804	SECHSKANTMUTTER M 10 HEXAGON NUT
10	139407	SCHRÄGSITZVENTIL 1" SLANTED-SEAT VALVE
11	116328	KUGELHAHN 3/4" BALL COCK
12	109851	SCHRÄGSITZVENTIL 1 1/4" SLANTED-SEAT VALVE

\* 21

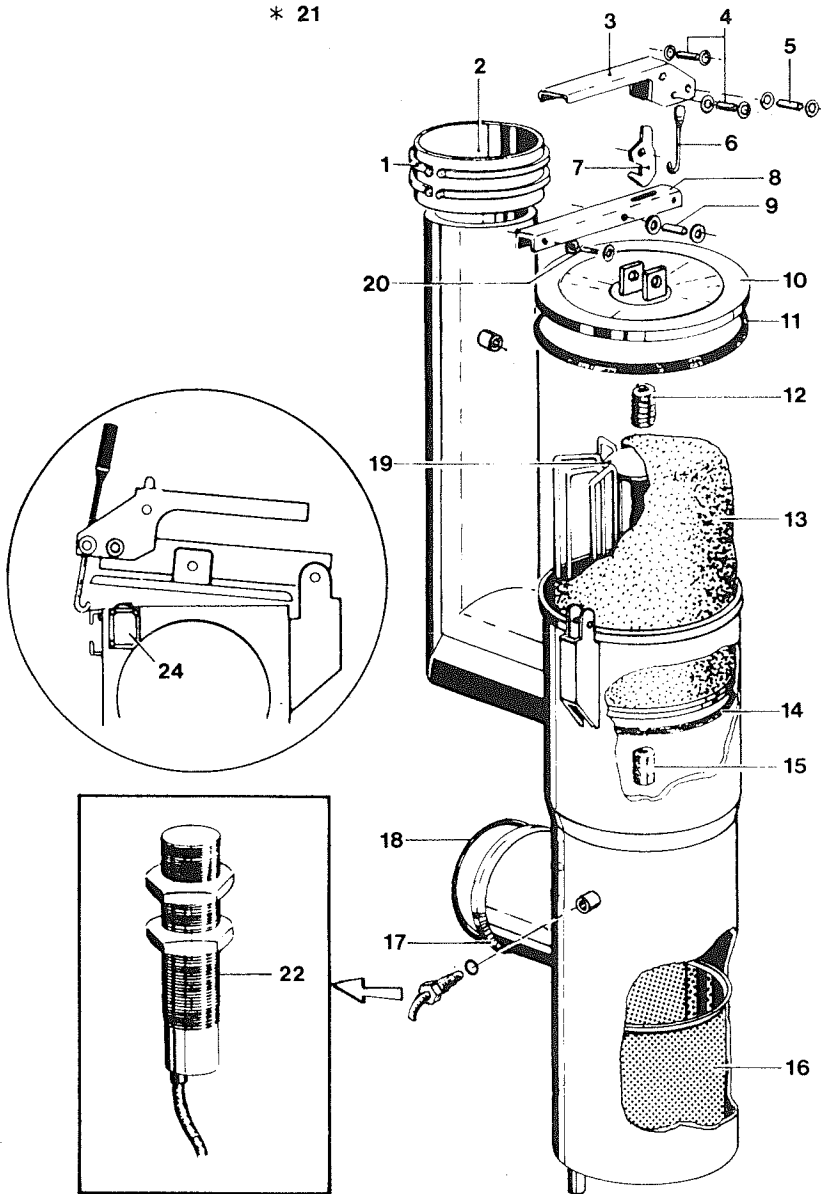

POS. ITEM	BESTELLNUMMER PART NUMBER	BENENNUNG DESIGNATION
1	125701	SCHLAUSCHELLE HOSE CLAMP
2	164515	SCHLAUCH HOSE
3	160729	GRIF F HANDLE
4	160731	BOLZEN OHNE KOPF HEADLESS BOLT
5	160776	BOLZEN OHNE KOPF HEADLESS BOLT
6	164386	TÜRVERSCHLUSS-SCHRAUBE SCREW LOCK
7	160728	VERSCHLUSS LOCK
8	163827	HEBEL LEVER
9	160733	BOLZEN OHNE KOPF HEADLESS BOLT
10	164385	DECKEL LID
11	164423	DICHTUNG GASKET
12	100375	DRUCKFEDER PRESSURE SPRING

POS. ITEM	BESTELLNUMMER PART NUMBER	BENENNUNG DESIGNATION
13	164387	FLUSENFILTER-TUCH LINT FILTER STRAINING CLOTH
14	164508	DICHTUNG GASKET
15	160730	DRUCKFEDER PRESSURE SPRING
16	198078	SIEBEINSATZ STRAINER
17	156040	SPANNSCHELLE CLAMP
18	151051	O-RING 172 X 7 O-RING
19	163881	FLUSENFILTER-KORB LINT FILTER BASKET
20	160732	BOLZEN OHNE KOPF HEADLESS BOLT
21	* 164380	NADELFÄNGER KOMPLETT BUTTON TRAP COMPLETE
22	168132	FÜLLSTANDSSENSOR LEVEL SENSOR
24	169930	ENDSCHALTER LIMIT SWITCH

POS. ITEM	BESTELLNUMMER PART NUMBER	BENENNUNG DESIGNATION
1	153513	DECKEL COVER
2	153512	DICHTUNG GASKET
3	153566	O-RING O-RING
4	156045	SPANNSCHELLE CLAMP
5	155803	BEHÄLTER EINSATZ TANK INSERT
6	155801	BEHÄLTER TANK
7	057037	DICHTSCHEIBE 28 X 40 X 4 GASKET
8	015526	SCHEIBE 28 X 42 X 8 WASHER
9	018026	SECHSKANTMUTTER 3/4" HEXAGON NUT
10	151083	KÜHLSCHLANGE CONDENSER COIL
11	153520	KONDENSATOR-KESSEL CONDENSER TANK
12	149873	SCHEIBE WASHER
13	016036	SECHSKANTMUTTER 1/2" HEXAGON NUT
14	022965	DICHTSCHEIBE 34 X 48 X 3 GASKET
15	076226	SCHEIBE WASHER
16	018027	SECHSKANTMUTTER HEXAGON NUT
17	161162	TEMPERATURSENSOR 40 - 180 °C THERMAL SENSOR
18	026364	FLANSCHDICHTUNG FLANGE GASKET
19	164928	STEIGROHR ASCENDING PIPE
20	031913	RÜCKSCHLAGKLAPPE 1/2" CHECK VALVE

POS. ITEM	BESTELLNUMMER PART NUMBER	BENENNUNG DESIGNATION
21	116976	DURCHGANGSVENTIL 1/8" THROUGH-WAY VALVE
22	091613	KÜHLWASSERREGLER 1/2" COOLING WATER REGULATOR
23	190908	WÄRMERÜCKFÜHRUNG KOMPLETT HEATING RECYCLING COMPLETE
24	015527	SCHEIBE 23 X 42 X 8 WASHER
25	148849	DISTANZBUCHSE SPACER
26	156755	EINSATZ KONDENSATOR INSERT CONDENSER
27	149281	DICHTUNG 28 X 35 X 4 GASKET
28	156040	SPANNSCHELLE CLAMP
29	151051	O-RING O-RING
30	156752	KÜHLSCHLANGE CONDENSER COIL
31	156753	BEHÄLTER TANK
32	113979	KUGELHAHN 1/2" BALL COCK
33	190909	KONDENSATOR KOMPLETT CONDENSER COMPLETE
34	151073	WÄRMETAUSCHER HEAT EXCHANGER

WÄRMERÜCKFÜHRUNG / HEAT RECYCLING

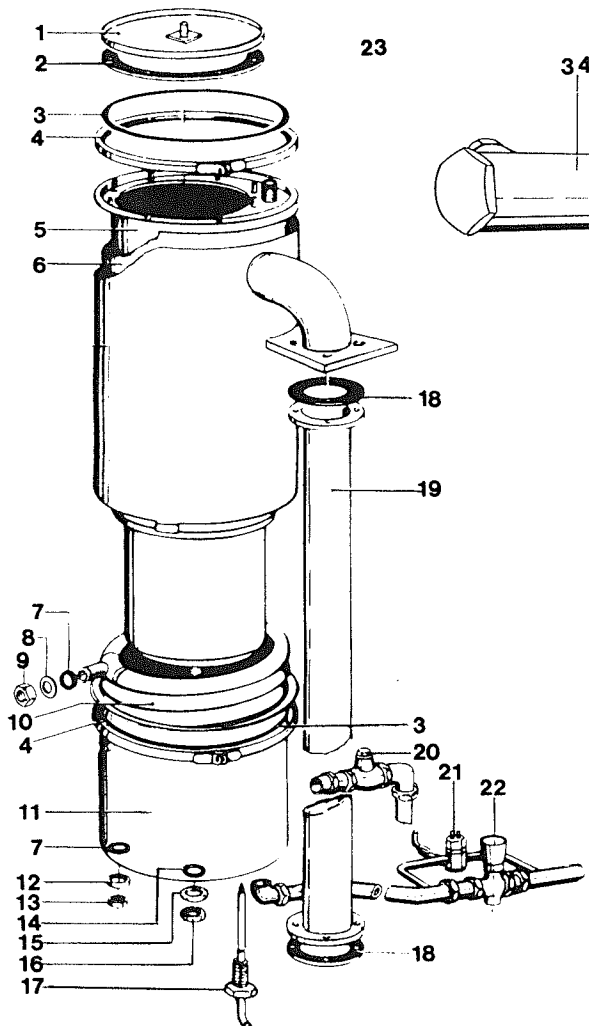

KONDENSATOR KOMPLETT / CONDENSER COMPLETE

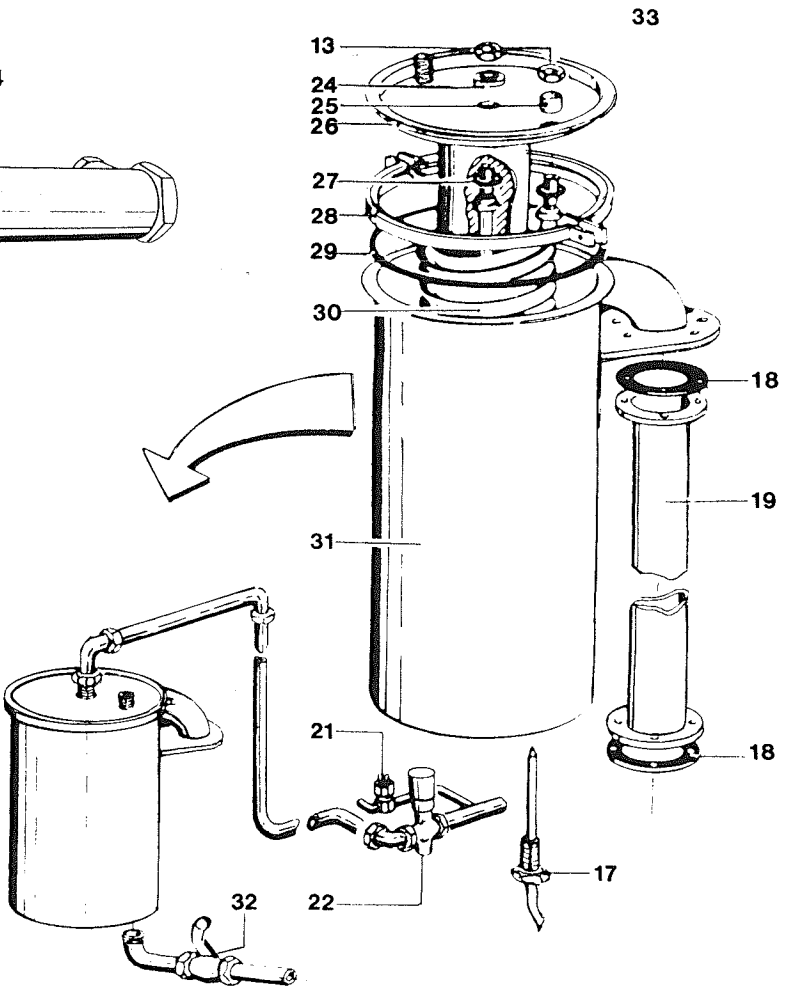

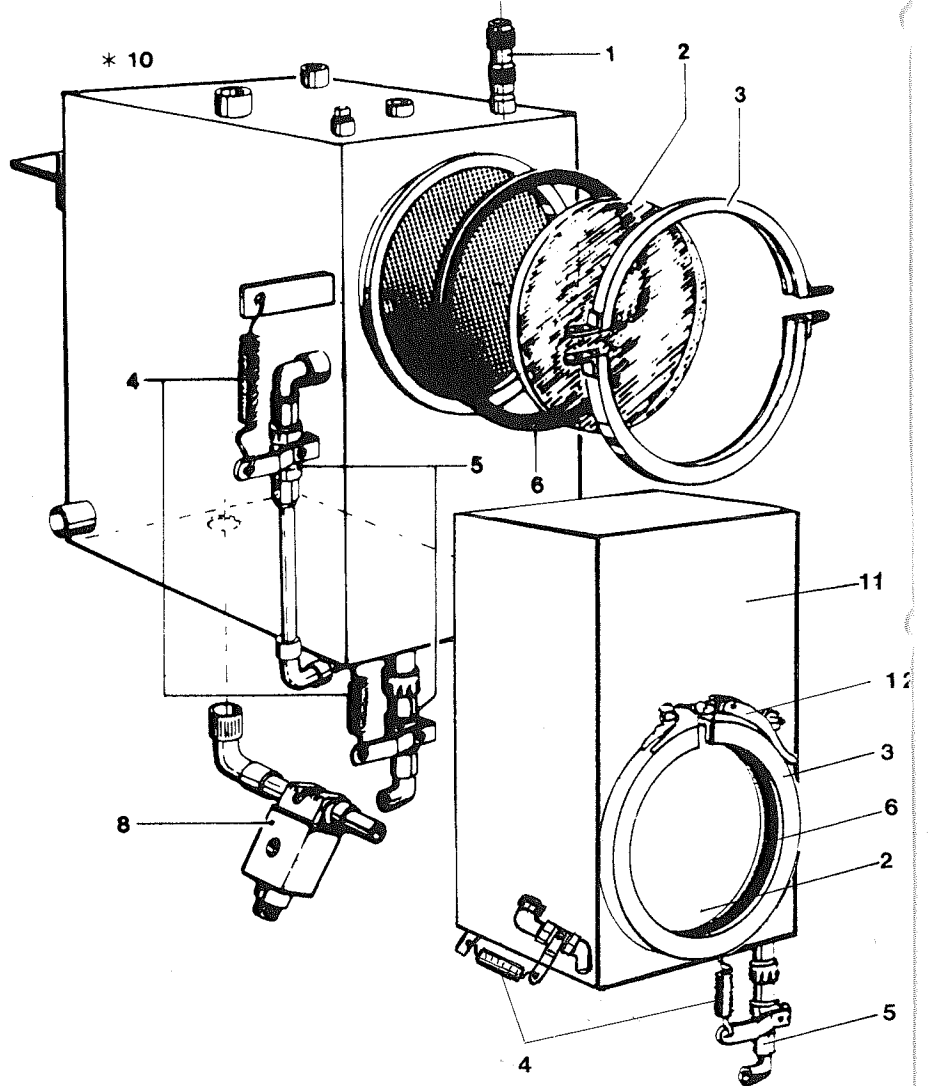
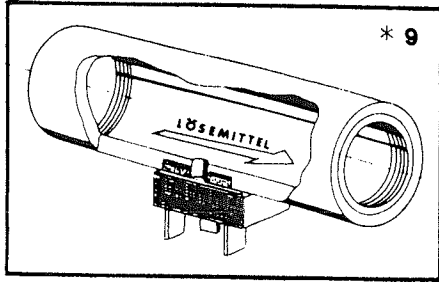

POS. ITEM	BESTELLNUMMER PART NUMBER	BENENNUNG DESIGNATION
1	168708	KUPPLUNG COUPLING
2	149288	GLASSCHEIBE GLASS
3	196290	SPANNSCHELLE CLAMP
4	047510	FEDER SPRING
5	113979	KUGELHAHN 1/2" BALL COCK
6	149253	DICHTUNG 177 X 181 X 9 GASKET

POS. ITEM	BESTELLNUMMER PART NUMBER	BENENNUNG DESIGNATION
8	116962	DURCHGANGSVENTIL 3/8" THROUGH-WAY VALVE
9	* 191778	TROCKENKONTROLLGERÄT DRYING CONTROLLER
10	* 159789	WASSERABSCHIEDER KOMPLETT WATER SEPARATOR COMPLETE
11	198568	NACHABSCHIEDER POST SEPARATOR
12	196505	KLAPPSTECKER FLAP PLUG

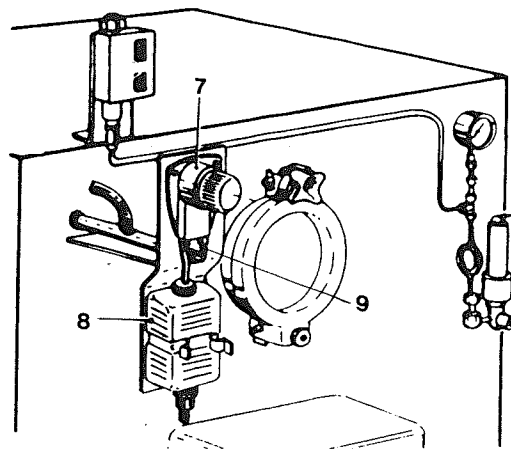
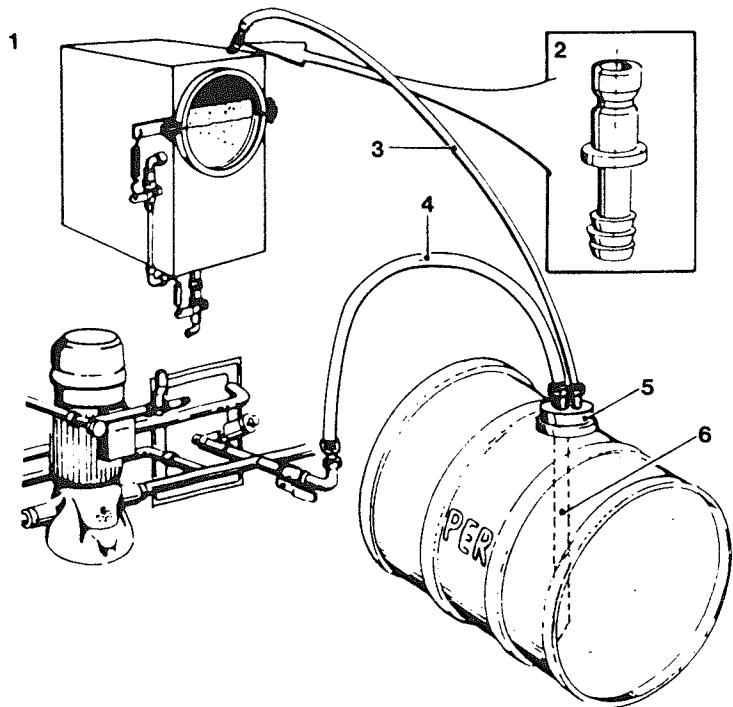

OS. ITEM	BESTELLNUMMER PART NUMBER	BENENNUNG DESIGNATION
	159689	LÖSEMITTELAUFFÜLLUNG KOMPLETT SOLVENT FILLING COMPLETE
	166063	STECKNIPPEL PLUG-IN NIPPLE
	206805	SCHLAUCH 10 X 2 X 3000 LANG HOSE
	129990	SCHLAUCH 19 X 4 X 2000 LANG HOSE
	166131	STOPFEN PLUG

POS. ITEM	BESTELLNUMMER PART NUMBER	BENENNUNG DESIGNATION
6	155991	TAUCHROHR IMMERSION PIPE
7	168722	HAND-DOSIERPUMPE (DESTILLATION) MANUAL DOSING PUMP (STILL)
8	166461	BEHÄLTER CONTAINER
9	169912	KUGELHAHN 1/4" BALL COCK

DG 18

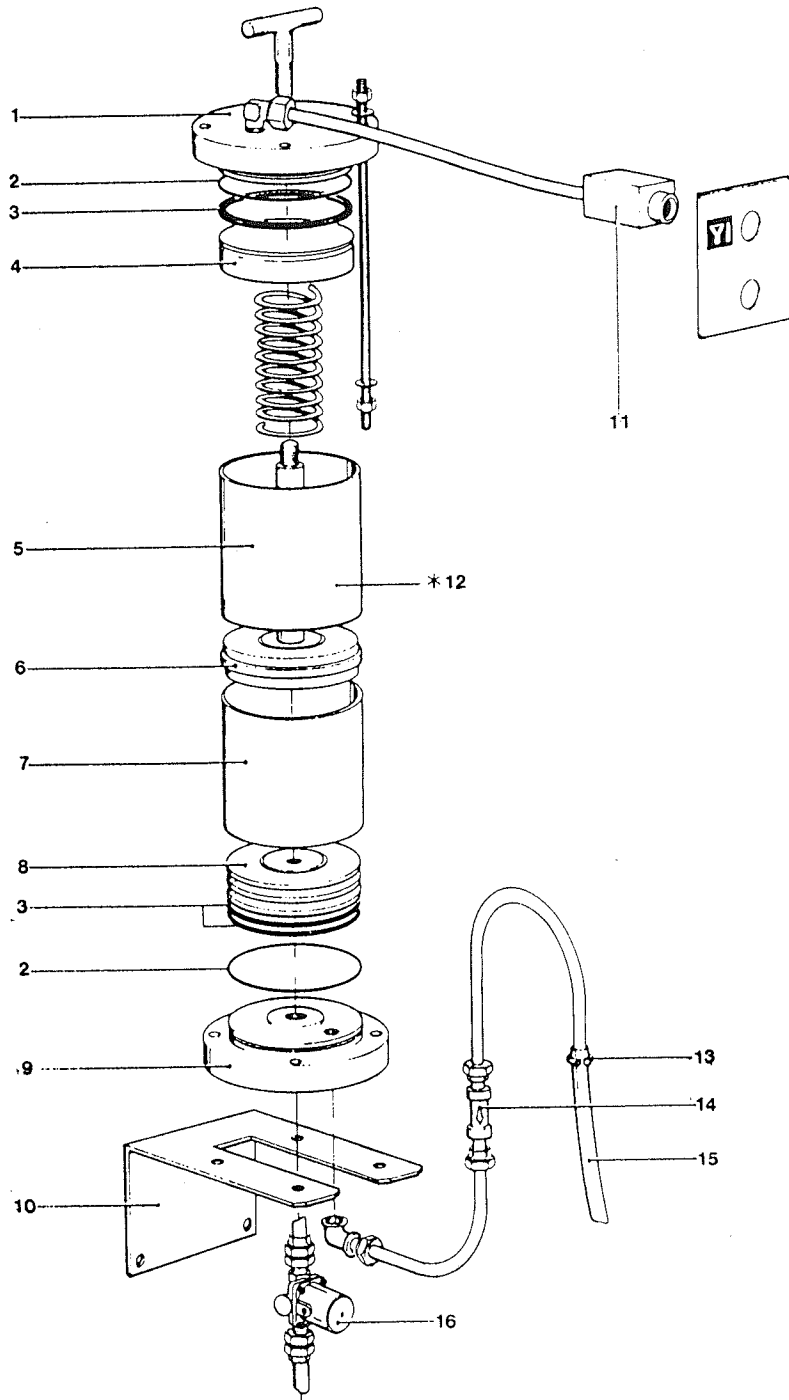

POS. ITEM	BESTELLNUMMER PART NUMBER	BENENNUNG DESIGNATION	POS. ITEM	BESTELLNUMMER PART NUMBER	BENENNUNG DESIGNATION
1	149292	FLANSCH DECKEL FLANGE LID	9	149291	FLANSCH BODEN FLANGE BASE
2	149368	O-RING 78 X 2 O-RING	10	160751	KONSOLE CONSOLE
3	149369	K-NUTRING K-PACKING RING	11	095885	DREIWEGEVENTIL R 1/8" SOLENOID VALVE
4	149365	KOLBEN ANDRUCK PISTON PRESSURE	12	148077	DOSIERGERÄT DG 18 DOSING UNIT DG 18
5	149294	HÜLSE DRUCKLUFT 76 X 80 BUSH COMPRESSED AIR	13	013024	SCHLAUCHSCHELLE HOSE CLAMP
6	149367	ZWISCHENPLATTE INTERMEDIATE PLATE	14	143002	RÜCKSCHLAGKLAPPE R 3/8" CHECK VALVE
7	149293	HÜLSE PRODUKT 76 X 80 BUSH PRODUCT	15	001795	SCHLAUCH 12 X 2 X 1300 LG HOSE
8	149366	KOLBEN PRODUKT PISTON PRODUCT	16	116962	DURCHGANGSVENTIL R 3/8" THROUGH-WAY VALVE



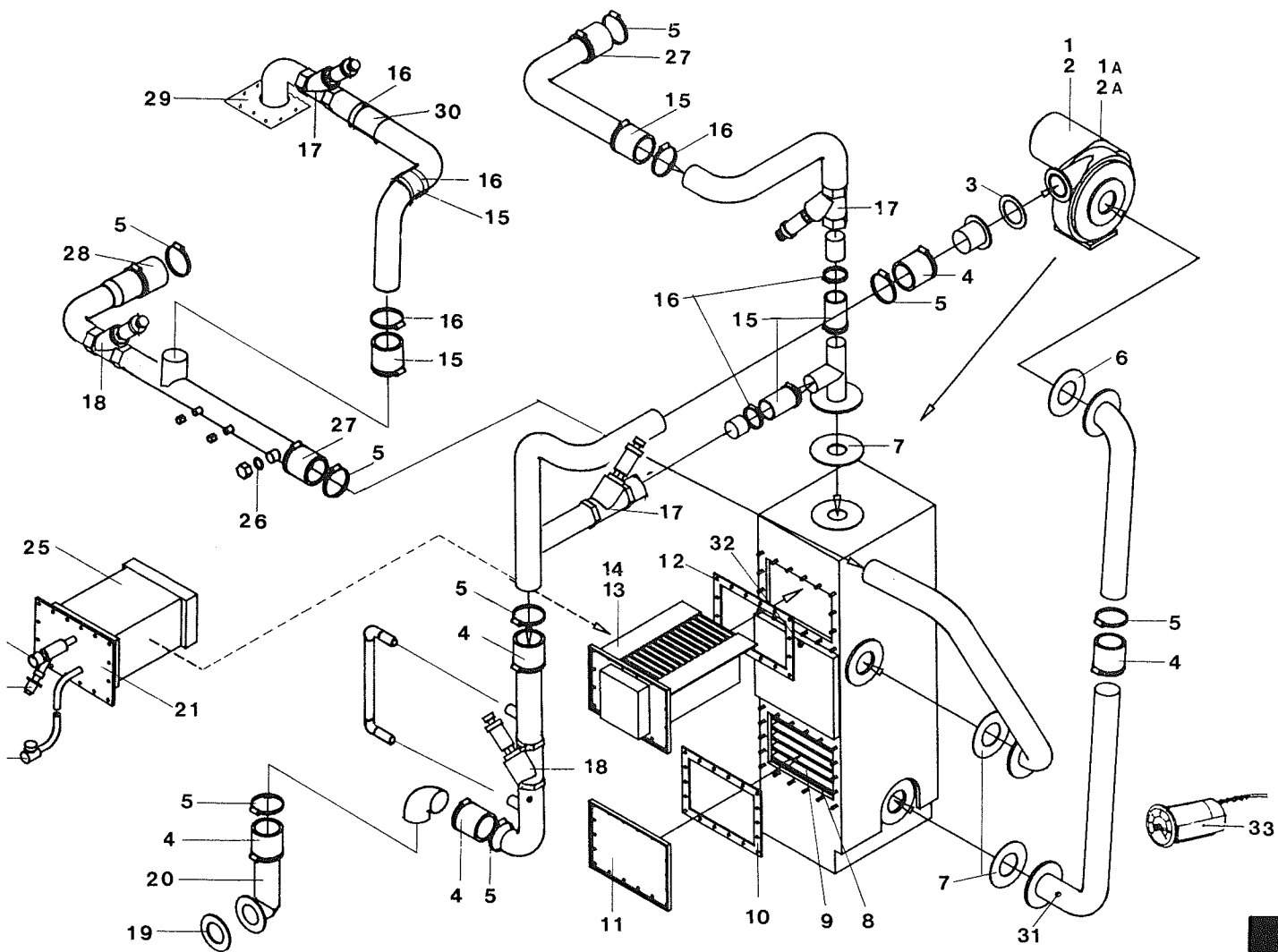

BESTELLNUMMER PART NUMBER	BENENNUNG DESIGNATION
196474	VENTILATOR 230 /400 V, 50 HZ FAN
191324	KEILRIEMEN 50 HZ V-BELT
169619	VENTILATOR 220 /380 V, 60 HZ FAN
191326	KEILRIEMEN 60 HZ V-BELT
166242	DICHTUNG GASKET
166251	SCHLAUCH 76 X 100 HOSE
119724	SCHLAUCHSCHELLE HOSE CLAMP
166243	DICHTUNG GASKET
194705	DICHTUNG GASKET
195826	KOHLEMATTE KOMPL. CARBON MAT
166778	KOHLEMATTE CARBON MAT
021311	DICHTUNG GASKET

POS. ITEM	BESTELLNUMMER PART NUMBER	BENENNUNG DESIGNATION
11	021310	DECKEL COVER
12	011288	DICHTUNG GASKET
13	197008	HEIZREGISTER 400 V HEATER
14	197009	HEIZREGISTER 230 V HEATER
15	166863	SCHLAUCH 60 X 120 HOSE
16	002196	SCHLAUCHSCHELLE HOSE CLAMP
17	169949	SCHRÄGSITZVENTIL SLANTED SEAT VALVE
18	166722	SCHRÄGSITZVENTIL SLANTED SEAT VALVE
19	164531	FLANSCHDICHTUNG GASKET
20	700068	ROHRLEITUNG PIPEWORK
21	011179	DECKEL LID
22	109360	ABLEITER STEAM TRAP

POS. ITEM	BESTELLNUMMER PART NUMBER	BENENNUNG DESIGNATION
23	031887	VENTIL CONTROL VALVE
24	031940	SCHMUTZFÄNGER STRAINER
25	169724	HEIZREGISTER DAMPF HEATER STEAM
26	074985	O-RING O-RING
27	166782	SCHLAUCH 76 X 135 HOSE
28	166250	SCHLAUCH 89 X 100 HOSE
29	700124	DECKEL LID
30	166864	SCHLAUCH 60 X 80 HOSE
31	161162	TEMPERATURSENSOR THERMAL SENSOR
32	163698	TEMPERATURSENSOR THERMAL SENSOR
33	090797	KONTAKTTHERMOMETER TEMPERATURE CONTROL GAUGE

WARTUNGSEINHEIT

MAINTENANCE UNIT

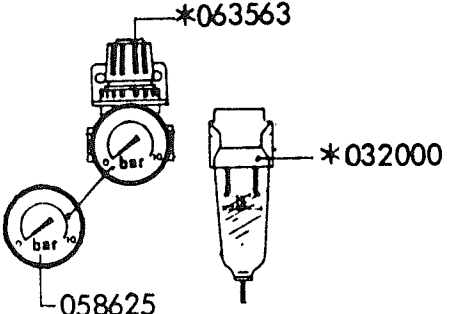

*063563	032000	Filterabscheider kompl. Separator compl.	1/4"
	058625	Röhrenfeder-Manometer Tubular pressure gauge	1/4"
	063563	Druckregelventil kompl. Pressure control valve compl.	1/4"

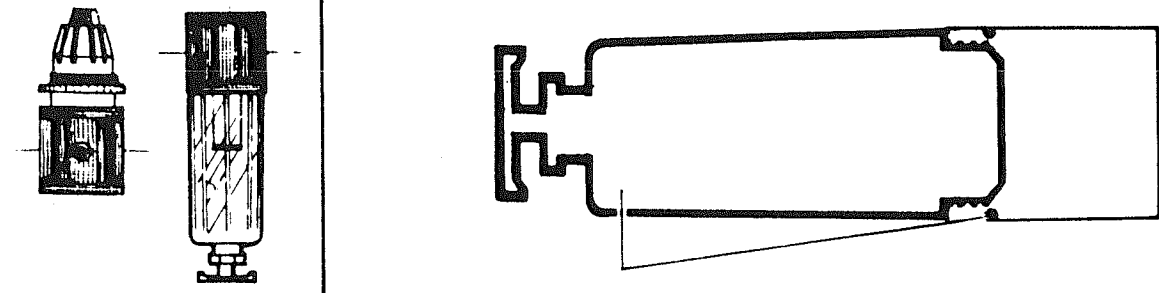

AIRCITY

122882

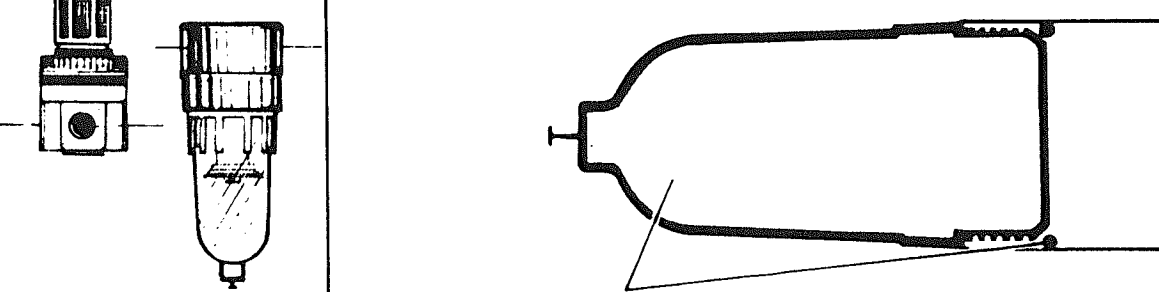

SMC

122880

BESTELLNUMMER  
PART NUMBER

BENENNUNG  
DESIGNATION

032000	FILTERABSCHIEDER KOMPL. 1/4." FILTER SEPARATOR COMPL.
058625	RÖHRENFEDER-MANOMETER 1/4" TUBULAR PRESSURE GAUGE
063563	LUFTVENTIL KOMPL. 1/4" PRESSURE CONTROL VLAVE COMPL.
122880	ET-PAKETE FÜR FILTERABSCHIEDER FA. SMC SPARES PACKAGE FOR FILTER SEPARATOR MESSRS. SMC
122882	ET-PAKETE FÜR FILTERABSCHIEDER FA. AIRCITY SPARES PACKAGE FOR FILTER SEPARATOR MESSRS. AIRCITY

KÜHLWASSERREGLER

COOLING WATER REGULATOR

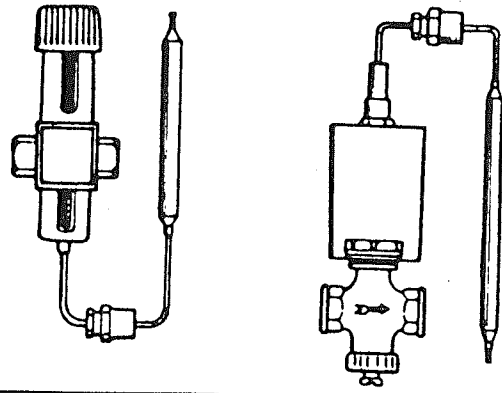

1/2 "	3/4 "	1 "		
* 091613	* 091614	* 091615		

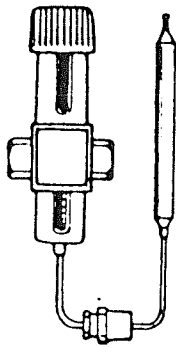

DANFOSS

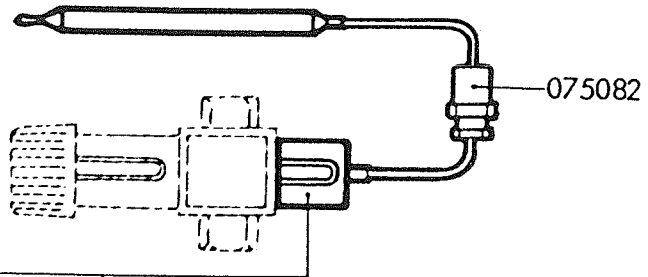

1/2 "	3/4 "	1 "		
103340				

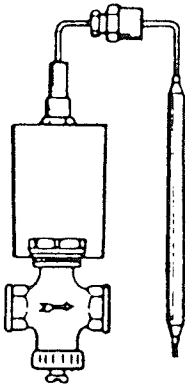

HERION

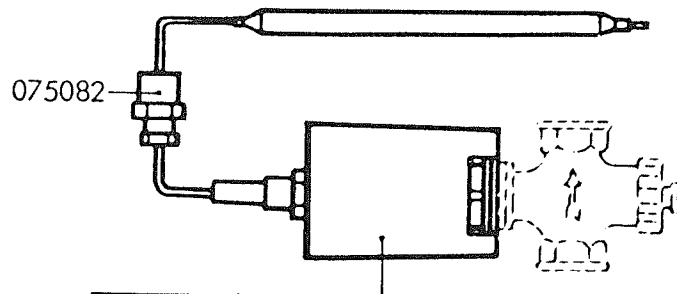

1/2 "	3/4 "	1 "		
148573				

- 075082      DICHTUNGSSATZ  
              SET OF GASKET
- 091613      KÜHLWASSERREGLER KOMPL. 1/2"  
              COOLING WATER REGULATOR COMPL.
- 091614      KÜHLWASSERREGLER KOMPL. 3/4"  
              COOLING WATER REGULATOR COMPL.
- 091615      KÜHLWASSERREGLER KOMPL. 1"  
              COOLING WATER REGULATOR COMPL.
- 103340      THERMOKAPSEL FA. DANFOSS  
              THERMOCAPSALE DANFOSS
- 148573      THERMOKAPSEL FA. HERION  
              THERMOCAPSALE HERION

**BESTELNUMMER  
PART NUMBER**

**BENENNUNG  
DESIGNATION**

---

116962	DURCHGANGSVENTIL KOMPL. 3/8" THROUGH-WAY VALVE COMPL
116976	DURCHGANGSVENTIL KOMPL. NW 1 mm 1/8" THROUGH-WAY VALVE COMPL
116977	ET-PAKET FÜR BÜRKERT-VENTIL 3/8" SPARES PACKAGE FOR BÜRKERT VALVE
116978	ET-PAKET FÜR MÜLLER-VENTIL 3/8" SPARES PACKAGE FOR MÜLLER VALVE
118524	ET-PAKET FÜR HERION-VENTIL 1/8" SPARES PACKAGE FOR HERION VALVE
123483	ET-PAKET FÜR SUCOMA-VENTIL 1/8" SPARES PACKAGE FOR SUCOMA VALVE
144923	DURCHGANGSVENTIL KOMPL. NW 2,4 mm 1/8" TROUGH-WAY VALVE COMPL

DURCHGANGSVENTIL

VALVE

3/8" SN 116962

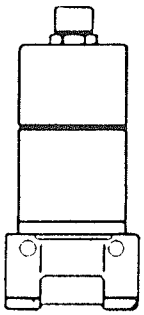

BÜRKERT

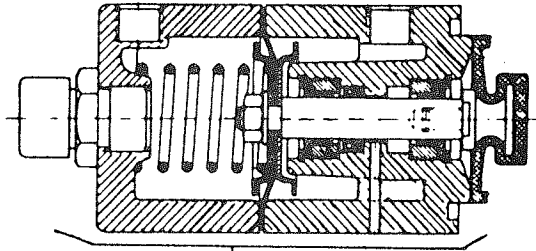

3/8"				
116977				

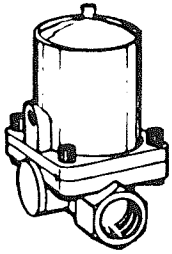

MÜLLER

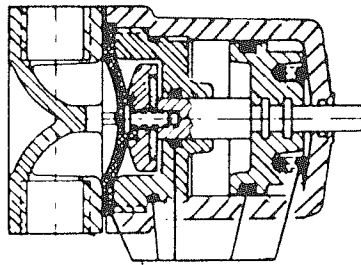

3/8"				
116978				

DURCHGANGSVENTIL

VALVE

1/8" SN 116976

1/8" SN 144923

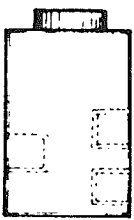

SUCOMA

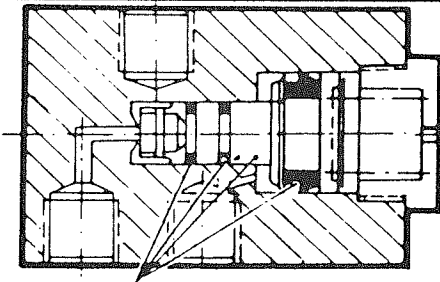

1/8"				
123483				

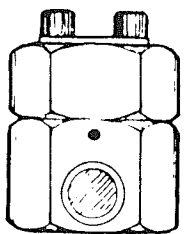

HERION

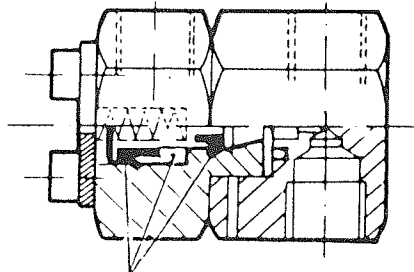

1/8"				
118524				

DAMPFVENTIL

STEAM VALVE

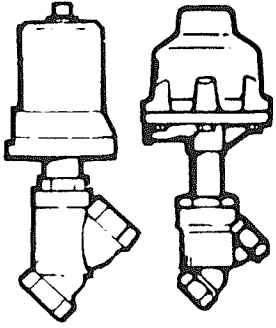

1/2"		1"	1 1/2"	2"
* 031887				

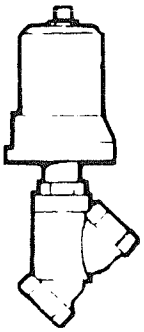

BÜRKERT

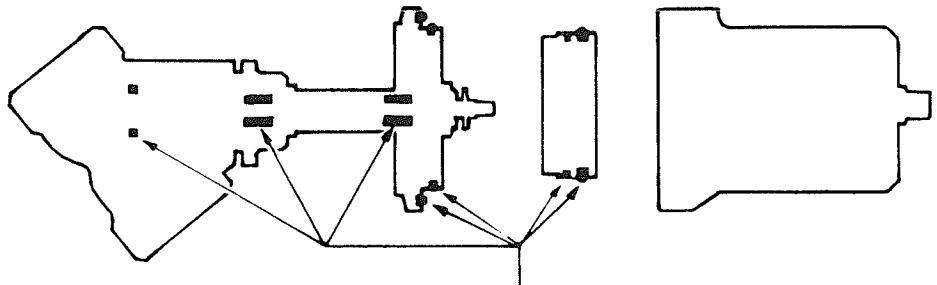

1/2"		1"	1 1/2"	2"
085266				

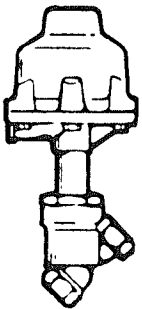

GEMÜ

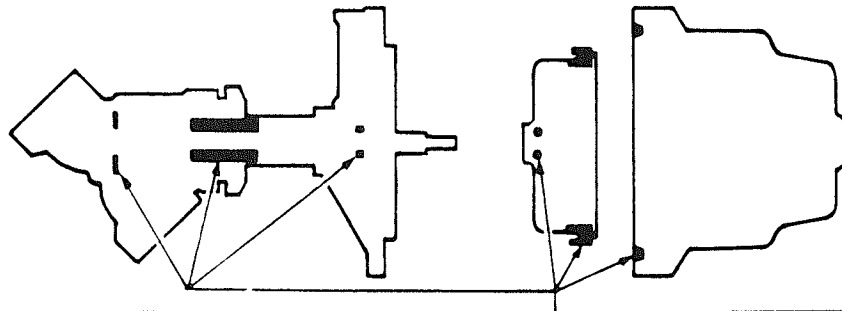

1/2"				
085296				

BESTELLNUMMER  
PART NUMBER

BENENNUNG  
DESIGNATION

031887

DAMPFVENTIL KOMPL. 1/2"  
STEAM VALVE COMPL.

085266

ET-PAKET FÜR BÜRKERT-VENTIL 1/2"  
SPARES PACKAGE FOR BÜRKERT VALVE

085296

ET-PAKET FÜR GEMÜ-VENTIL 1/2"  
SPARES PACKAGE FOR GEMÜ VALVE

SCHRÄGSITZVENTIL  
SLANTING-SEAT VALVE

2"	2 1/2"	3"
* 169949	* 166722	* 166721

2"	2 1/2"	3"
193803	193804	193805

ET-PAKET  
SPARES-PACKAGE

ET-PAKET  
SPARES-PACKAGE

1/2"	3/4"	1"	1 1/4"	1 1/2"	2"
* 013543 + 161105	*109850	*139407	*109851	*164226	*161310

1/2"	3/4"	1"	1 1/4"	1 1/2"	2"
195975	195976	195977	196044	190949	190944





MAGNETVENTIL

SOLENOID VALVE

\* 144830

FA. STAIGER

\* 144831

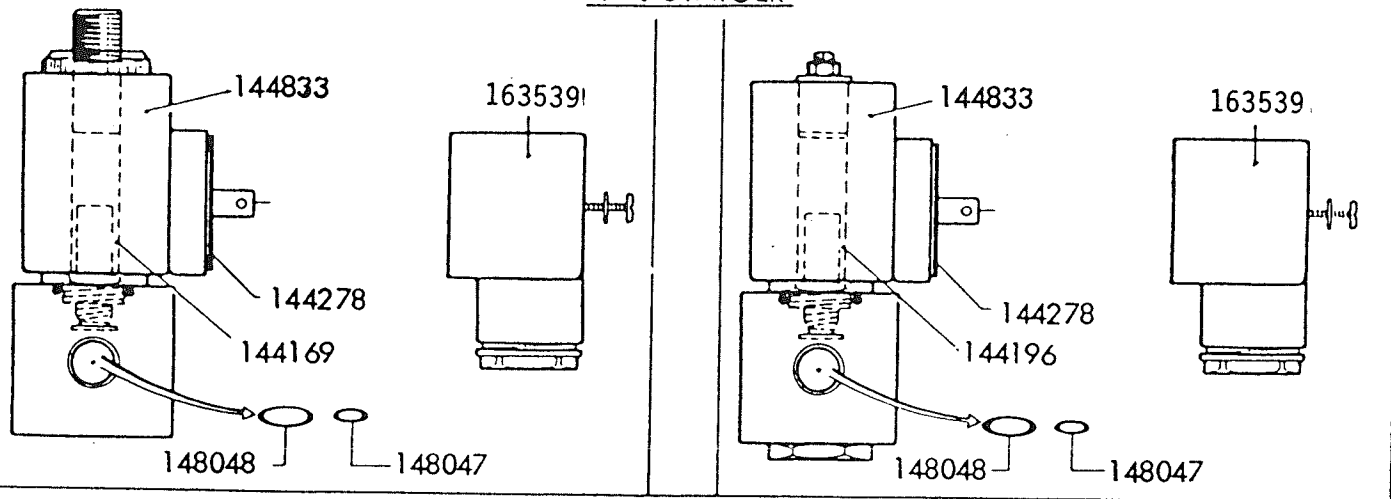

BESTELLNUMMER PART NUMBER	BENENNUNG DESIGNATION
------------------------------	--------------------------

144169	PLUNGER KOMPL. STROMLOS GESCHLOSSEN PLUNGER COMPL. CLOSED WITHOUT CURRENT
144196	PLUNGER KOMPL. STROMLOS GEÖFFNET PLUNGER COMPL. OPEN WITHOUT CURRENT
144278	DICHTUNG GASKET
144830	MAGNETVENTIL STROMLOS GESCHLOSSEN 24 V GLEICHSTROM SOLENOID VALVE CLOSED WITHOUT CURRENT 24 V DIRECT CURRENT
144831	MAGNETVENTIL STROMLOS GEÖFFNET 24 V GLEICHSTROM SOLENOID VALVE OPEN WITHOUT CURRENT 24 V DIRECT CURRENT
144833	MAGNETSPULE 24 V GLEICHSTROM MAGNET COIL 24 V DIRECT CURRENT
148047	O-RING 7 X 1,5 O-RING
148048	O-RING 14 X 1,5 O-RING
163539	GERÄTESTECKER RECEPTABLE

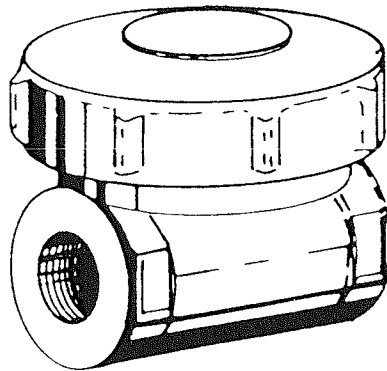

<b>BESTELLNUMMER</b>	<b>BENENNUNG</b>
<b>PART NUMBER</b>	<b>DESIGNATION</b>

---

109360	KONDENSATABLEITER 1/2" TYP BPT 13sx SPIRAX-SARCO KOMPL. CONDENSATE TRAP TYPE BPT 13sx SPIRAX-SARCO COMPL.
--------	--

165287	BYMETALL-ELEMENT BIMETAL ELEMENT
--------	-------------------------------------

DURCHGANGSSCHAUGLAS

TUBULAR SIGHT-GLASS

		3/4"		1"		1 1/2"		2"		2 1/2"	
		I		II		I		II			
		A									
		B									
		C									
		III		III							
		126241		109865							
		A									
		B									

PRESSLUFTZYLINDER

PNEUMATIC RAM

		3/4" - 1"		1 1/4" - 1 1/2"		2" KNORR PERMAC		2 1/2" KNORR PERMAC	
		*						031 863 35/66    031 863 35/66	
A								142035    142036	
B									
C									
D									

- 05 SCHAUGLAS KOMPLETT 1 1/4" SIGHT-GLASS COMPLETE 126241 SCHAUGLAS KOMPL. 3/4" SIGHT-GLASS COMPL.
- 63 PRESSLUFTZYLINDER KOMPL. 2 1/2" PNEUMATIC RAM 129238 STECKFASSUNG SOCKET
- 65 SCHAUGLAS KOMPL. 1" SIGHT-GLASS COMPL. 142035 ET-PAKET FÜR KNORR-ZYLINDER 35/66 ET-SPARES FOR KNORR RAM 35/66
- 37 GLÜHLAMPE 24 V 3 W BULB 142036 ET-PAKET FÜR PERMAC-ZYLINDER 35/66 ET-SPARES FOR PERMAC RAM 35/66

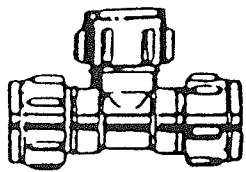

Verschraubung T-Stück  
T iron

22 x 22 x 22	SN 155759
28 x 28 x 28	SN 155760
42 x 42 x 42	SN 160830
35 x 35 x 35	SN 163702

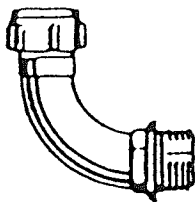

Einschraubbogen  
Threaded elbow

18 x 1/2"	SN 156628
22 x 3/4"	SN 155743
28 x 1"	SN 155744
35 x 1 1/4"	SN 163828

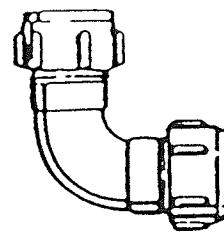

Bogen  
Elbow

22 x 22	SN 155717
28 x 28	SN 155718
35 x 35	SN 163704

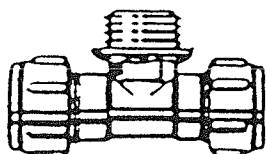

Einschraub-T-Stück  
Threaded T iron

22 x 1/2" x 22	SN 155766
22 x 3/4" x 22	SN 155767
28 x 1" x 28	SN 155854

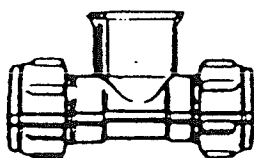

Muffen-T-Stück  
Sleeve iron

28 x 3/4" x 28	SN 155772
28 x 1/2" x 28	SN 161249

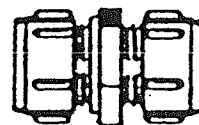

Gerade Verschraubung  
Straight union

15 x 15	SN 156554
12 x 12	SN 161388
18 x 18	SN 153578
22 x 22	SN 153580
28 x 22	SN 153581
28 x 28	SN 153582
42 x 42	SN 160765
54 x 54	SN 160764

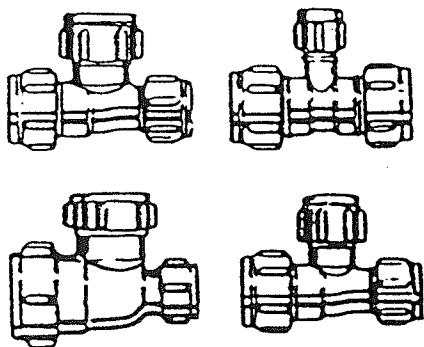

Reduziertes T-Stück  
Reduced T iron

15 x 12 x 15	SN 157853
18 x 18 x 15	SN 156602
18 x 15 x 15	SN 161246
22 x 15 x 22	SN 156629
22 x 28 x 22	SN 157857
28 x 22 x 22	SN 157855
28 x 22 x 28	SN 157856
28 x 28 x 22	SN 157858
28 x 15 x 28	SN 161245
28 x 28 x 15	SN 163701

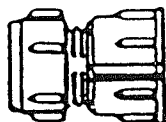

Muffen-Verschraubung  
Sleeve union

15 x 1/2"	SN 155687
15 x 3/4"	SN 155688
22 x 1/2"	SN 155691
22 x 3/4"	SN 155692
22 x 1"	SN 155693
28 x 3/4"	SN 155694
28 x 1"	SN 155695

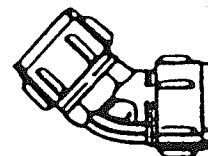

Winkel-Verschraubung  
Elbow

28 x 28	SN 155714
---------	-----------

KLEMMRING-VERSCHRAUBUNGEN  
CLAMPING RING UNIONS

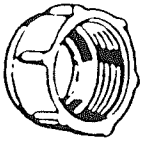

Überwurfmutter  
Clamping nut

12	SN 153568
15	SN 153569
18	SN 153570
22	SN 153571
28	SN 153572



Klemmring  
Clamping ring

12	SN 153573
15	SN 153574
18	SN 153575
22	SN 153576
28	SN 153577

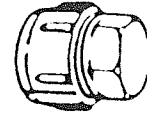

Verschlußstück  
Screw cap

12	SN 155697
15	SN 155698
18	SN 155699
22	SN 155701
28	SN 155702



Einschraubverschraubung  
on. Rohrgewinde  
ipe union conical  
ipe thread

15	x	1/2"	SN 153595
18	x	1/2"	SN 155681
22	x	3/4"	SN 155683
22	x	1"	SN 155684
28	x	3/4"	SN 155685
28	x	1"	SN 155686

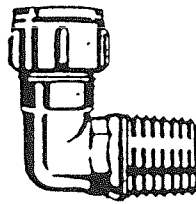

Einschraubwinkel  
konisch  
Threaded angle  
conical

12	x	3/8"	SN 155732
15	x	3/8"	SN 155734
15	x	1/2"	SN 155735
18	x	1/2"	SN 155738
22	x	3/4"	SN 155739
28	x	1"	SN 155741

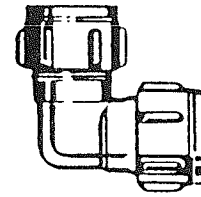

Winkel-Verschraubung  
Elbow

12	x	12	SN 155703
15	x	15	SN 155706
18	x	18	SN 155708
22	x	15	SN 155709
22	x	22	SN 155710
28	x	22	SN 155711
28	x	28	SN 155712
28	x	15	SN 163777



Einschraub-  
verschraubung  
Pipe union

0	x	1/2"	SN 161250
2	x	3/8"	SN 153583
2	x	1/2"	SN 153584
5	x	3/8"	SN 153585
5	x	1/2"	SN 153586
8	x	1/2"	SN 153587
8	x	3/4"	SN 156601
2	x	1/2"	SN 153588
2	x	3/4"	SN 153589
8	x	1"	SN 153590
8	x	3/4"	SN 153591
8	x	1"	SN 153592
2	x	1 1/2"	SN 160763
5	x	1"	SN 163703
5	x	1 1/4"	SN 163755

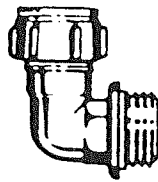

Einschraubwinkel  
Threaded angle

12	x	3/8"	SN 155719
12	x	1/2"	SN 155720
15	x	3/8"	SN 155721
15	x	1/2"	SN 155722
18	x	1/2"	SN 155724
22	x	1/2"	SN 155726
22	x	3/4"	SN 155727
28	x	3/4"	SN 155729
28	x	1"	SN 155730
35	x	1 1/4"	SN 163699

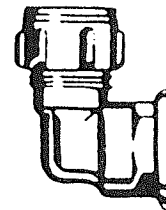

Muffenwinkel  
Sleeve angle

15	x	1/2"	SN 155748
18	x	1/2"	SN 155750
22	x	1/2"	SN 155752
22	x	3/4"	SN 155753
22	x	1"	SN 155754
28	x	3/4"	SN 155755
28	x	1"	SN 155756
35	x	1 1/4"	SN 163700

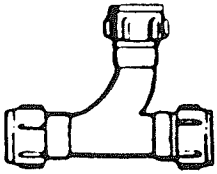

T-Stück mit einem gebogenen Abzweig  
T iron with curved branch

22 x 22 x 22 SN 155762  
28 x 28 x 28 SN 155763  
35 x 35 x 35 SN 163829

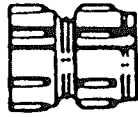

Muffen-Verschraubung mit kurzem Innengewinde  
Sleeve union with short inside thread

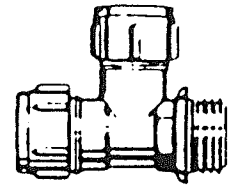

Einschraub-T-Stück  
Threaded iron

15 x 15 x 1/2" SN 1557  
22 x 22 x 3/4" SN 1557  
22 x 22 x 1" SN 1557

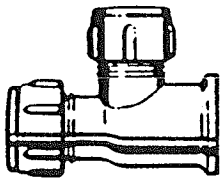

Muffen-T-Stück  
Sleeve iron

22 x 22 x 1/2" SN 155778  
28 x 28 x 1/2" SN 161244  
28 x 28 x 1" SN 155902

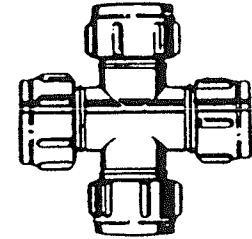

Kreuzstück  
Crosspiece

22 x 22 x 22 x 22 SN 1559  
28 x 28 x 28 x 28 SN 1637

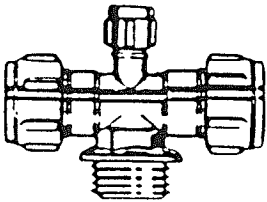

Einschraub-T-Stück  
Threaded T iron

22 x 3/4" x 1/8" SN 157912

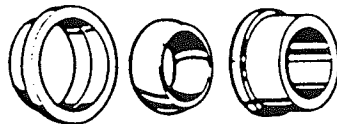

Reduzierringe  
Reducing washers

28 x 22 SN 160837

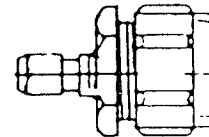

Gerade Verschraubung  
Straight union

22 x 1/8" SN 157911

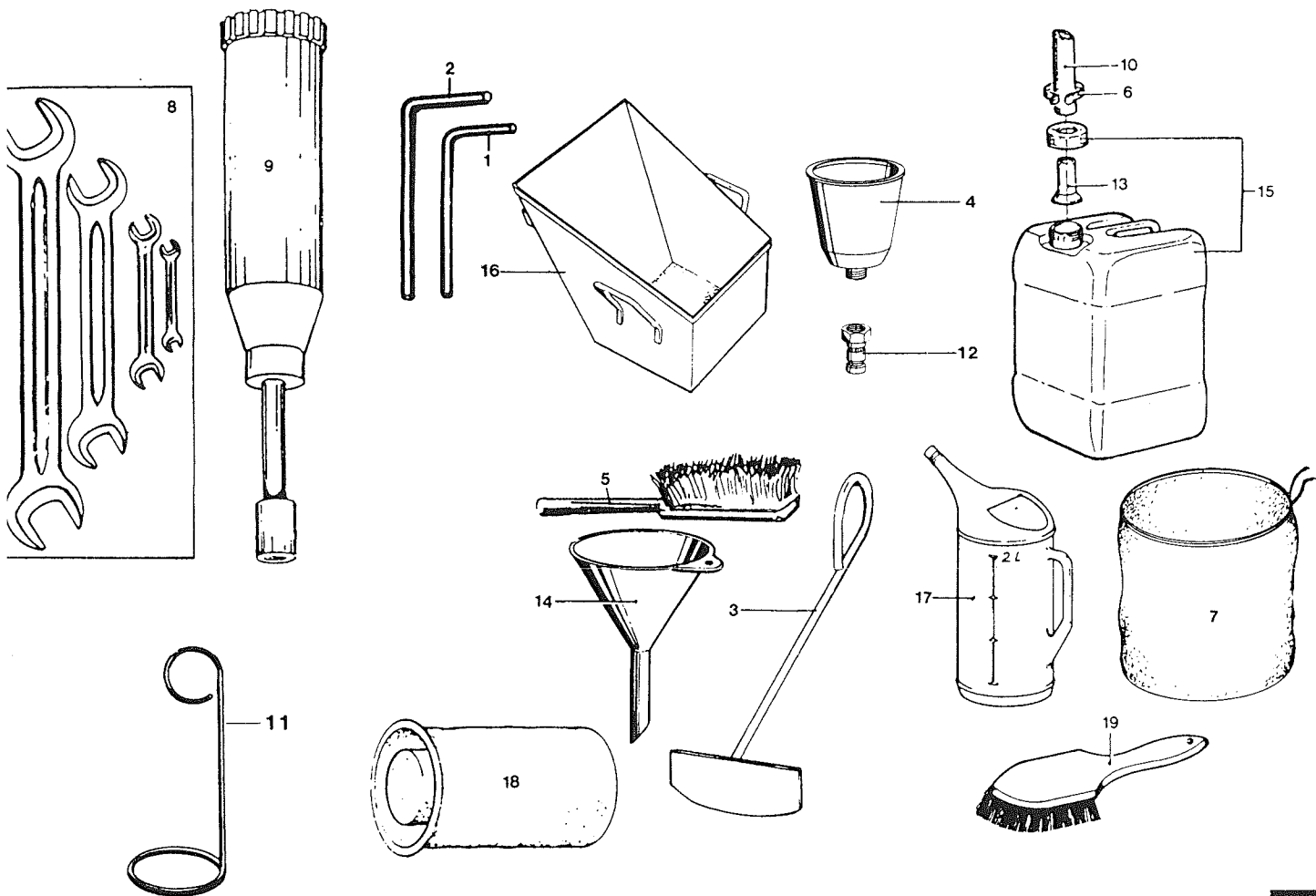

BESTELLNUMMER PART NUMBER	BENENNUNG DESIGNATION	POS. ITEM	BESTELLNUMMER PART NUMBER	BENENNUNG DESIGNATION
002018	SECHSKANTSCHLÜSSEL 5 mm HEXAGON WRENCH	12	166348	STECKNIPPEL PLUG-IN NIPPLE
002019	SECHSKANTSCHLÜSSEL 6 mm HEXAGON WRENCH	13	128979	ROHRSTUTZEN PIPE SOCKET
018562	KRATZER SCRAPER	14	129617	TRICHTER FUNNEL
166327	EINFÜLLTRICHTER FILLING FUNNEL	15	129243	WASSERBEHÄLTER WATER CONTAINER
032551	STIELBÜRSTE BRUSH	16	139455	AUSRÄUMWANNE CLEAN-OUT THROUGH
045650	SCHLAUCHSCHELLE HOSE CLAMP	17	148109	MESSBECHER MEASURING CUP
103546	FILTERPULVERSACK FILTER POWDER BAG	18	164387	FLUSENFILTER-TUCH LINT FILTER STRAINING CLOTH
053196	DOPPELMAUL-SCHLÜSSEL DOUBLE-HEAD WRENCH	19	161478	STIELBÜRSTE BRUSH
074173	FETTPRESSE GREASE GUN	--	148236	INDIKATORPAPIER INDICATOR PAPER
078523	SCHLAUCH 16 X 2,5 mm HOSE	--	148324	REGENERIERPULVER REGENERATING POWDER
166423	EINSCHUBBÜGEL PUSH-IN TOOL			







# **BÖWE PASSAT**

Reinigungs- und Wäschereitechnik GmbH

Postfach 1013 80, D-86003 Augsburg

Telefon (08 21) 5702 01, Fax (08 21) 570 23 51, Tx 536480 boe d